

# **FUEL PERMEATION FROM AUTOMOTIVE SYSTEMS**

**Final Report**

**CRC Project No. E-65**

**September 2004**

**Prepared for:**

**California Environmental Protection Agency**

---



**Air Resources Board**

**1001 I Street - Sacramento, California 95814**

and



**Coordinating Research Council, Inc.**  
**3650 Mansell Road, Suite 140 - Alpharetta, Georgia 30022**

# **FUEL PERMEATION FROM AUTOMOTIVE SYSTEMS**

## **Final Report CRC Project No. E-65**

Prepared by:

Harold M. Haskew, P.E.  
Thomas F. Liberty  
**Harold Haskew & Associates, Inc.**  
Milford, Michigan

Dennis McClement  
**Automotive Testing Laboratories, Inc.**  
Mesa, Arizona

**September 2004**

**Table of Contents**

<b><u>Section</u></b>	<b><u>Page No.</u></b>
Abstract	1
Introduction	2
The CRC E-65 Project Steering Committee	4
Conclusions, Findings and Recommendations	5
Test Program Overview	6
Fleet Selection	16
Test Rig Construction	19
Fuel Properties	21
Data Collection and Quality Control	26
Correction for Ethanol in SHED Measurements	26
Reducing Uncertainty in Steady-State Measurements	27
The First Hour Anomaly – A Theory	30
Stabilization Technique	30
The Quality Control Rig	33
Gas Chromatograph Speciation Procedures	35
Results	36
Stabilization at 105° F	37
Diurnal Measurements	39
Speciation Results (Diurnal)	40
Specific Reactivity Calculations	45
Increase in Non-Ethanol HC with Fuel B	51
Steady-State Test Results - 105°F and 85°F	53
Estimate of Experimental Variation	57
Effect of Fill Level (100% vs. 20%)	59
Appendices	
A - Evaporative Emissions	60
B - A Vehicle's Fuel System	61
C - Isolating the Breathing Losses	62
D - Evaporative Emissions Control Regulations	64
E - Sealed Housing for Evaporative Determination	65
F – Carter Reactivity Scale – MIR	67
G – Diurnal Emissions Comparison	78
H – Individual Laboratory Fuel Inspections	80

**List of Figures**

<b><u>Fig. No.</u></b>	<b><u>Title</u></b>	<b><u>Page No.</u></b>
1	Fleet Selection	16
2	California MY Fleet Distribution	16
3	Test Rig 9	20
4	Canister and Controls Mounting	20
5	Test Rig 4	20
6	Incremental Permeation Rate – Example 1	27
7	Weekly Stabilization Results	28
8	Incremental Permeation Rate – Example 2	29
9	Incremental Permeation Rate – Example 3	30
10	Stabilization Testing	32
11	The <u>Quality Control</u> Rig	33
12	QC Stabilization Testing – Average of Hours Two and Three	34
13	QC Stabilization Testing – Four Week Running Average	34
14	Stabilization Testing – All Rigs, All Fuels	37-38
15	Average Diurnal Permeation vs. Model Year	40
16	Specific Reactivity of Permeate – Average & 95% C.L.	50
17	Non-Ethanol Increase in Ethanol Fuel – Stabilization	51
18	Non-Ethanol Increase in Ethanol Fuel – Diurnal	52
19	Permeation Rates 85 vs 105 °F	54
20	Permeation Rates 85 vs 105 °F – Rig 5 Omitted	55
21	Relationship Between Diurnal and Stabilized Permeation	56
22	Diurnal Emissions – Average & 95% C.L.	58
	<b><u>Appendices</u></b>	
23	Vehicle Fuel System Schematic	61
24	Evaporative Emission Control	61
25	Calculated Equilibrium Concentrations	62
26	Test Rig 2	63
27	Open Bottom Canister	63
28	ATL SHEDs	66

**List of Tables**

<b>Table No.</b>	<b>Title</b>	<b>Page No.</b>
1	Fleet Selection	17
2	Fleet Specifications	18
3	Liquid Fuel Speciation Comparison	22-23
4	Fuel Inspections	24
5	Detailed Hydrocarbon Analysis	25
6	Permeation Test Results – Example 1	26
7	Permeation Test Results – Example 2	31
8	Average Diurnal Values	39
9	Speciation Results	41-44
10	Reactivity Calculation Example	46
11	Average Reactivity of Permeate for Fuel A	47
12	Average Reactivity of Permeate for Fuel B	48
13	Average Reactivity of Permeate for Fuel C	49
14	Reactivity of Permeate – All Fuels	49
15	Permeation Rates	53
16	85 to 105 Ratio	54
17	Replicate Diurnal Test Results	57
18	Diurnal Emissions	58
19	Fill Level Effect – Steady-state Results	59
	<b><u>Appendices</u></b>	
20	Diurnal Increase Fuel A to Fuel B	78
21	Diurnal Increase Fuel C to Fuel B	78
22	Diurnal Comparison Fuel A and Fuel C	79

### Abstract

The California Air Resources Board (CARB), in cooperation with the Coordinating Research Council (CRC), sponsored a major study on the permeation effects of ethanol on automotive fuel systems. Permeation is a diffusion process whereby fuel molecules migrate through the elastomeric materials (rubber and plastic parts) that make up the vehicle's fuel and fuel vapor systems. Permeation is a component of the evaporative emissions from the vehicle fleet.

The need for a study of the permeation effects of ethanol became apparent when in late 1999 California banned the use of MTBE in gasolines. With this ban, which became effective starting in calendar year 2004, ethanol became the only oxygenate approved for use in California gasolines. California must quantify the permeation effects of ethanol because California's statutes require that any increase in fuel emissions be off-set with a similar reduction from other sources. The year-round use of oxygenated gasoline in severe and extreme ozone non-attainment areas is a federal government requirement that applies to about 80 percent of the gasoline sold in California. The CARB petitioned the Environmental Protection Agency to waive the oxygenate requirement for California's gasoline, stating that complying gasolines could be blended without the use of an oxygenate. However, a waiver has not yet been granted.

The study was first proposed at a public meeting in Sacramento on June 21, 2001. The CRC offered to support and co-fund the program. Contracts were awarded in March 2002, but funding availability delayed the formal commitment until late in 2002.

This test program was designed to determine the magnitude of the permeation differences between three fuels, containing either MTBE, ethanol, or no oxygenate, in the selected test fleet. The testing was conducted on a sample of ten California vehicles chosen to represent the light-duty in-use fleet as it existed in calendar year 2001. The oldest was a 1978 Oldsmobile Cutlass, and the newest was a 2001 Toyota Tacoma pick-up truck. Vehicles were identified and purchased in late 2002.

The vehicle's liquid and vapor fuel systems were removed and installed on aluminum frames (rigs) for evaluation. Special care was taken to remove the complete system without disconnecting any of the components. The rig mounted systems were stabilized at 105°F with a 100% fill of each of the test fuels.

The emission tests were conducted between January 2003 and June 2004. Emission measurements included steady-state permeation rates at 105 and 85°F, and 48-hour diurnal measurements using the California test procedure (65 to 105 to 65°F). All emissions samples were analyzed for hydrocarbons and specific oxygenates, and average reactivities were calculated from the speciation results for all three fuels. Repeat diurnal tests were performed using the non-oxygenated fuel to establish an estimate of the repeatability of the experiment. The coefficient of variation (COV) (standard deviation/ mean level) for the diurnal results was estimated at 8%.

Emissions increased on all 10 vehicle fuel systems studied when ethanol replaced the MTBE in the test gasolines. The average permeation emissions with a 5.7 volume % ethanol gasoline were 1.40 grams/day higher than permeation emissions with the MTBE gasoline and 1.10 grams/day higher than permeation emissions with a non-oxygenated gasoline. This is equivalent to an average permeation emissions increase of 65% with a change from the MTBE gasoline to the ethanol gasoline and 45% with a change from the non-oxygenated gasoline to the ethanol gasoline. The average permeation difference between the MTBE fuel and the non-

oxygenate fuel was 0.30 grams/day. The differences between the ethanol fuel and the others are statistically significant at the 95% confidence level. The differences between the MTBE and the non-oxygenated fuel are not statistically significant. The results of this study apply to 5.7% ethanol blended gasoline as used in California, but may not necessarily apply to higher concentration ethanol blends or different gasoline compositions. This report with detailed results of the test program has been posted on the CRC's web-site at [www.crao.com](http://www.crao.com) and on CARB's web-site at [www.arb.ca.gov/fuels/gasoline/gasoline.htm](http://www.arb.ca.gov/fuels/gasoline/gasoline.htm).

The rigs with non-metallic fuel tanks were evaluated to determine if permeation emissions varied with fill level. The base program stabilized the permeation at 100% fill. Additional testing was performed at 20% fill. Mixed results were obtained – the newer systems had less permeation after the 20% stabilization; the mid-90s tanks had little effect or an increase.

### **Introduction**

California has achieved significant improvements in air quality in the last decade. An important contribution to the State's progress has been the regulation of gasoline properties to reduce motor vehicle emissions. California's Phase 1 gasoline regulation, which took effect in 1992, banned the use of lead, required the use of deposit control additives, and placed further limits on volatility. The Phase 2 regulations, which took effect in 1996, required extensive changes to gasoline composition, including specifications for oxygen at the levels required by the federal government. Under federal law as defined in the Clean Air Act Amendments of 1990 (Section 211 (k)(2)(B)), severe and extreme ozone non-attainment areas of the country are required to use "reformulated" gasoline as one of their attainment strategies. This reformulated gasoline must contain at least an average of 2% (by weight) oxygen year round. Two oxygenates are commonly used, Methyl Tertiary-Butyl Ether (MTBE) and ethanol (EtOH).

The effects of MTBE use were studied by University of California researchers, and based on the study's findings and public testimony, the governor issued Executive Order D-5-99, dated March 25, 1999, stating that there was a significant risk to the environment from using MTBE in gasoline in California. The Executive Order D-5-99 directed specific action to be taken by appropriate state agencies including the ARB to ban the use of MTBE and investigate the environmental effects of alternative oxygenates. Among other tasks, the ARB was specifically directed to do the following:

- Adopt Phase 3 (CaRFG3) regulations to provide flexibility in lowering or removing oxygenates while maintaining air quality benefits of the existing ReFormulated Gasoline program (RFG)
- Request a waiver from the federal year round oxygenate requirement on California's gasoline.

With the ban on MTBE effective December 31, 2003, ethanol is currently the only oxygenate approved for use in California gasoline. Under the governor's Executive Order, various state agencies evaluated the environmental impact of ethanol use. One impact of concern was the potential for ethanol-containing gasolines to increase the rate of permeation of fuel components through materials used in vehicle fuel systems. Permeation is the migration or diffusion of fuel molecules through the elastomeric materials (rubber and plastic parts) that make up the vehicle's fuel and fuel vapor systems. Permeation is a component of the daily evaporative emissions from a vehicle, but the effect due to ethanol use was not adequately quantified when the ARB adopted the Phase 3 RFG regulations in 1999. This report does not assess

permeation emissions from non-automotive sources such as fuel storage and distribution facilities, portable storage containers, etc.

This test program, (CRC E-65 Program), was designed to determine the magnitude of the permeation effect on the selected vehicle systems. The objective was to measure the permeation emissions of California-compliant gasolines containing MTBE, ethanol, or no oxygenate in vehicle systems representative of the light-duty in-use fleet as it existed in calendar year 2001. The study was initiated by the CARB staff and proposed by Harold Haskew & Associates, Inc.<sup>1</sup> of Milford, MI at a public meeting in Sacramento on June 21, 2001. The CRC asked to participate and offered to co-fund the program. Harold Haskew was selected to provide the program administration. Automotive Testing Laboratories (ATL)<sup>2</sup> was selected to provide the testing services for the study. Contracts were awarded in March of 2002, but funding availability delayed the formal commitment until late in 2002. The emission tests were conducted during a period that ran between January 2003 and June 2004. This report presents the results of the experimental test program.

We offer page number references at each item to speed the reader to the pertinent section. Second, because of the voluminous data, we have offered example listings of the underlying data, and referred the reader to a "Companion CD-ROM", available through the CRC<sup>3</sup> by request, or available as a down-load from the CARB web-site ([www.arb.ca.gov/fuels/gasoline/gasoline.htm](http://www.arb.ca.gov/fuels/gasoline/gasoline.htm)). Third, we have included background information about permeation as a component of evaporative emissions, the SHED technique for measuring evaporative emissions, and the history of evaporative emission regulations.

---

<sup>1</sup> Harold Haskew & Associates, Inc., 425 W. Huron, Suite 230, Milford, MI 48381 Phone (248) 684-3410

<sup>2</sup> Automotive Testing Laboratories, 263 S. Mulberry St., Mesa, AZ 85202 Phone (480) 649-7906

<sup>3</sup> Coordinating Research Council (CRC), 3650 Mansell Road, Suite 140, Alpharetta, GA 30022, (678) 795-0506, "www.CRCAO.com"

**The CRC E-65 Project Steering Committee**

The Coordinating Research Council (CRC) is a non-profit organization that directs, through committee action, engineering and environmental studies on the interaction between automotive equipment and petroleum products. The Sustaining Members of CRC are the American Petroleum Institute (API), the Society of Automotive Engineers (SAE) and a group of automobile manufacturers (Ford, General Motors, DaimlerChrysler, Honda, Toyota and Volkswagen).

The E-65 project was directed by a steering committee of 18 members, including representatives of vehicle manufacturers, the petroleum industry, CARB staff, and the Renewable Fuels Association.

Members were:

<b>Gary Herwick</b> Co-Chair	General Motors
<b>Mike Ingham</b> Co-Chair	ChevronTexaco
Brent Bailey	Coordinating Research Council
Loren Beard	DaimlerChrysler
Tim Belian	Coordinating Research Council
Steve Brisby	California Air Resources Board
Steve Cadle	General Motors
Dominic DiCicco	Ford Motor Company
King Eng	Shell Global Solutions
Frank Gerry	British Petroleum
Albert Hochhauser	ExxonMobil
Stuart Johnson	Volkswagen of America
David Lax	American Petroleum Institute
Hannah Murray	Toyota
Mani Natarajan	Marathon Ashland
Robert Reynolds	Renewable Fuels Association
Dean Simeroth	California Air Resources Board
Jim Uihlein	British Petroleum
Ken Wright	ConocoPhillips

### **Conclusions, Findings and Recommendations**

**Conclusions** - Based on the results of this study, and subject to all the limitations of the project plan and scope, the following can be concluded:

1. Gasoline containing ethanol at a level of 2.0 weight percent oxygen increased the permeation of the tested California vehicle systems, compared to gasoline with MTBE as the oxygenate at the same oxygen content, or a similar gasoline made without any oxygenate; these changes in emissions were statistically significant at the 95% level for the diurnal data. The non-oxygenated fuel did not produce a statistically significant change in permeation relative to the MTBE fuel. (Page 39)
2. Non-ethanol hydrocarbon permeation emissions generally increased when the ethanol containing fuel was tested. (Pages 51-52)
3. The average specific reactivities of the permeate from the three test fuels were similar. The specific reactivities of the permeate of the MTBE and ethanol fuels (Fuels A and B) were not statistically different on average. The non-oxygenated fuel (Fuel C) permeate was higher than the other two with a statistically significant difference. (Pages 44-50)
4. Permeation rates measured at different temperatures followed the relationship predicted in the literature, nominally doubling for a 10° C rise in temperature. (Pages 53-55)
5. A consistent relationship between the 105°F steady-state permeation rate and the variable temperature 24-hour diurnal permeation rate was observed on all three fuels. (Page 56)
6. Vehicles certified to the newer “enhanced” evaporative emission standards (phased in from the 1996 to 1998 model years) had lower permeation emissions, including those with non-metallic fuel tanks. (Pages 39-40)
7. The non-metallic fuel tank systems of the early 1990s (Rigs 5 and 6) exhibited relatively high permeation emissions on all test fuels compared to the other systems tested. (Pages 39-40)
8. Permeation rates from the two newest non-metallic fuel tank systems (Rigs 2 and 4) exhibited a sensitivity to fill level. The emissions were lower when there was less fuel in the tank. (Page 59)
9. Permeation emissions (105°F steady-state) generally approached a stabilized level within 1 to 2 weeks when switching from one fuel to another. (Page 37)

### **Findings** -

1. The average increase of the diurnal permeation emissions was 1.40 g/day for the ethanol fuel compared to the MTBE fuel (Fuel B compared to Fuel A). The individual rig increases ranged from 0.34 to 2.71 g/day. (Appendix G - Page 78)

2. The average increase of the diurnal permeation emissions was 1.10 g/day for the ethanol fuel compared to the non-oxygenated fuel (Fuel B compared to Fuel C). The individual rig increases ranged from -0.15 to 2.90 g/day. (Appendix G – Page 78)
3. The average specific reactivities (MIR – g Potential Ozone/g VOC) of the permeate emissions from the three fuels, and the 95% multiple comparison limits about those averages were found to be (Page 49):

MTBE Fuel	3.47 ± 0.107
Ethanol Fuel	3.27 ± 0.102
Non-Oxygenated Fuel	3.66 ± 0.075

4. The average 105°F steady-state permeation rates ranged from 9.4 to 801 milligrams per hour (mg/hour) on the ten rigs and the three tested fuels. (Page 53)
5. The ratios between the 85 and 105°F permeation rates, on average, were (Page 54):

MTBE Fuel	0.42
Ethanol Fuel	0.46
Non-Oxygenated Fuel	0.46

**Recommendations** – *It is recommended that this study be expanded to assess the newer California LEV II compliant vehicles.* The data and understandings collected during this test program are limited to the in-use fleet vehicles that existed at the time this study was initiated. The California LEV II requirements lowered the evaporative emissions (3-day Diurnal + Hot Soak) limits from 2.0 g/day to 0.5 g/day starting with model year 2004 vehicles. These new technology vehicles should be evaluated in the same fashion as was done in this study

*It is also recommended that a similar study be done on E10 fuel.* While the data were collected at ethanol levels currently used in California (5.7%), ethanol is commonly used at 10% in other parts of the country.

### **Test Program Overview**

The objective of this test program was to measure the permeation emissions of California compliant gasolines containing ethanol, MTBE, or no oxygenate, in vehicle systems representative of the California in-use fleet as it existed in calendar year 2001.

A test fleet of 10 vehicles was chosen. ATL procured the vehicles for testing from California retail sources, brought the vehicles to the laboratory in Arizona, and carefully inspected the vehicles to insure that the original fuel system was present and in good repair. After passing this initial inspection, the lab personnel removed the entire fuel system intact (without making any disconnections to the liquid or vapor system), and fabricated an aluminum rack or “rig” that held the components in their approximate x, y and z positions.

Each test rig was filled with test fuel and stored in a test room at 105°F until evaporative testing determined that stabilization of the permeation emissions was achieved. Each rig had the fuel in it circulated twice a week, and all fuel was drained and fresh fuel was installed every seventh

week. Once each week, each rig was removed from the soak chamber, and placed in a hot soak SHED<sup>4</sup> at a temperature of 105°F for 3 hours to estimate the current permeation rate.

After the rig's permeation rate was stabilized at 105°F, and approved by the Steering Committee, it was tested at 85°F and then prepared for a California 2-day diurnal (65 to 105 to 65°F) emission test.

The constant temperature tests were performed in a 105°F or 85°F hot soak SHED<sup>5</sup> for a three-hour test period, with the emissions measured during the last two hours. All fixed temperature (105° and 85°F) testing was performed in ATL SHED 14. Variable temperature diurnal (65° to 105° to 65°F) testing was performed in ATL SHEDs 13 and 15. These three SHEDS are variable volume/variable temperature (VV/VT) equipment that can be operated in fixed or variable temperature modes.

The fuel tanks and the canisters were vented to the outside of the SHED to eliminate the possibility of the tank venting emissions being counted as permeation. Emission rates were calculated using the 2001 California certification test procedure.

The fuel was drained from the rig, and a 40% fresh fill of the appropriate test fuel added. The rig was then placed in a VT-SHED, the canister vented to the outside, and the California 2-day diurnal procedure performed. Samples of the ambient air in the VT-SHED<sup>5</sup> were taken at the start of the diurnal and at the end of day 1 and day 2 for later hydrocarbon speciation analysis.

The details of the procedures are shown schematically in Chart 1 through Chart 8.

---

<sup>4</sup> SHED – Sealed Housing for Evaporative Determination

<sup>5</sup> A hot soak SHED is used for constant temperature evaporative emission tests. A variable temperature SHED (VT-SHED) differs in that it has hardware capable of changing the internal ambient temperature as required, and a means for compensating for the volume change associated with that temperature change. A 65 to 105°F temperature swing produces a 7.6% volume change, if the pressure remains constant. A VT-SHED can be used to conduct a constant temperature test.

Chart 1  
**E65 Program Overview**

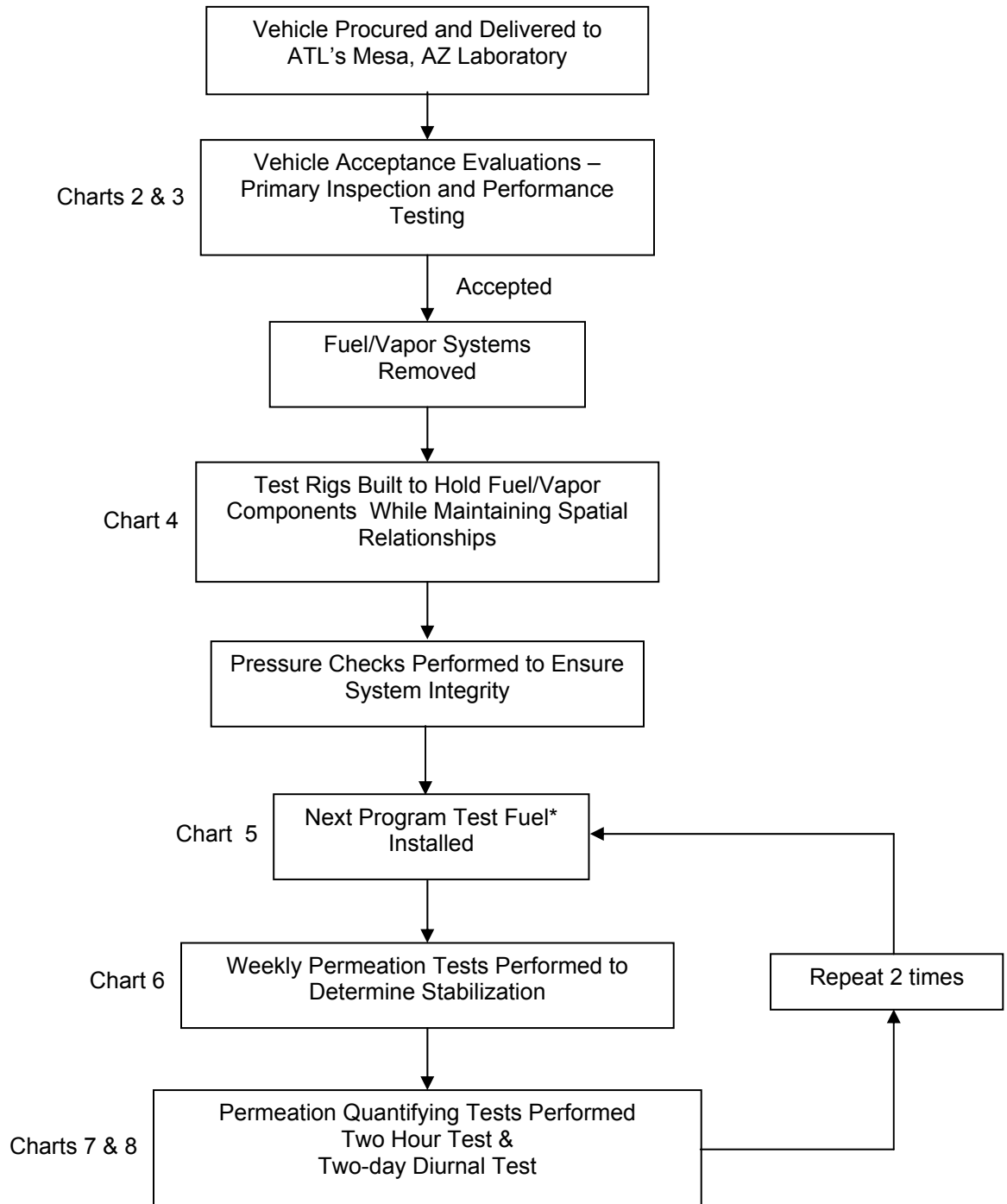

\* Program Test Fuels

1. California Fuel w/~11 vol% MTBE
2. California Fuel w/~5.7 vol% Ethanol
3. California Type Non-Oxygenated Fuel

Chart 2  
**Vehicle Acceptance Evaluation**  
**Step 1 – Procurement and Primary Inspection**

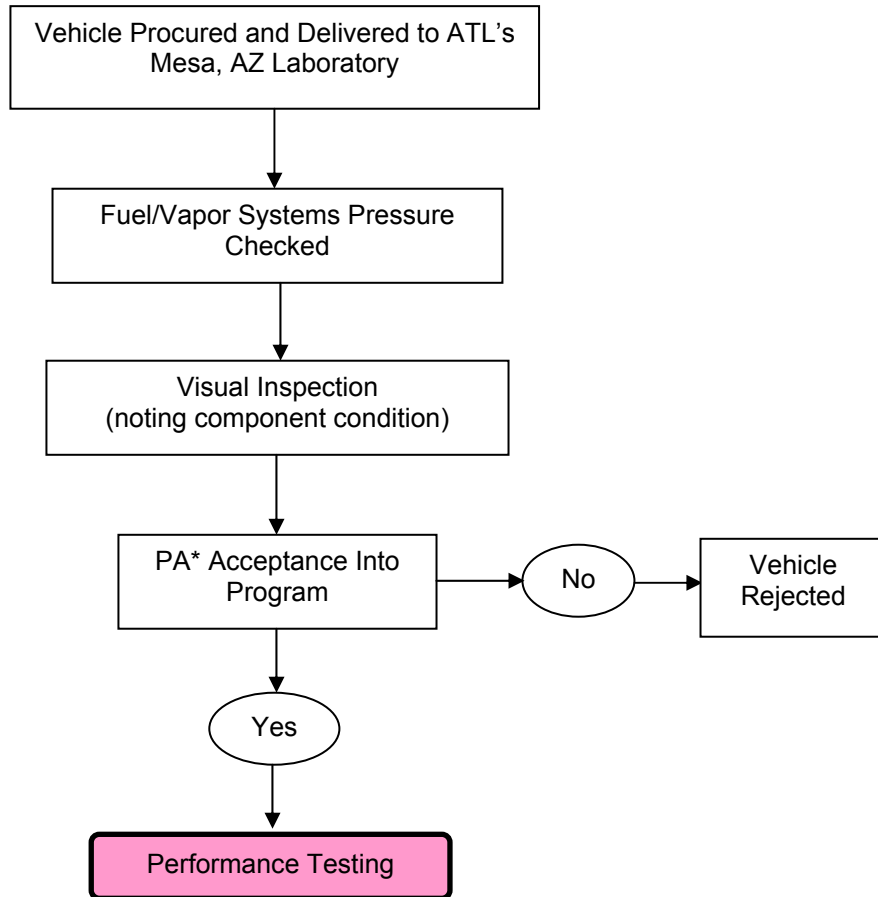

\* = Program Administrator

Chart 3  
**Vehicle Acceptance Evaluation  
 Step 2 - Performance Testing**

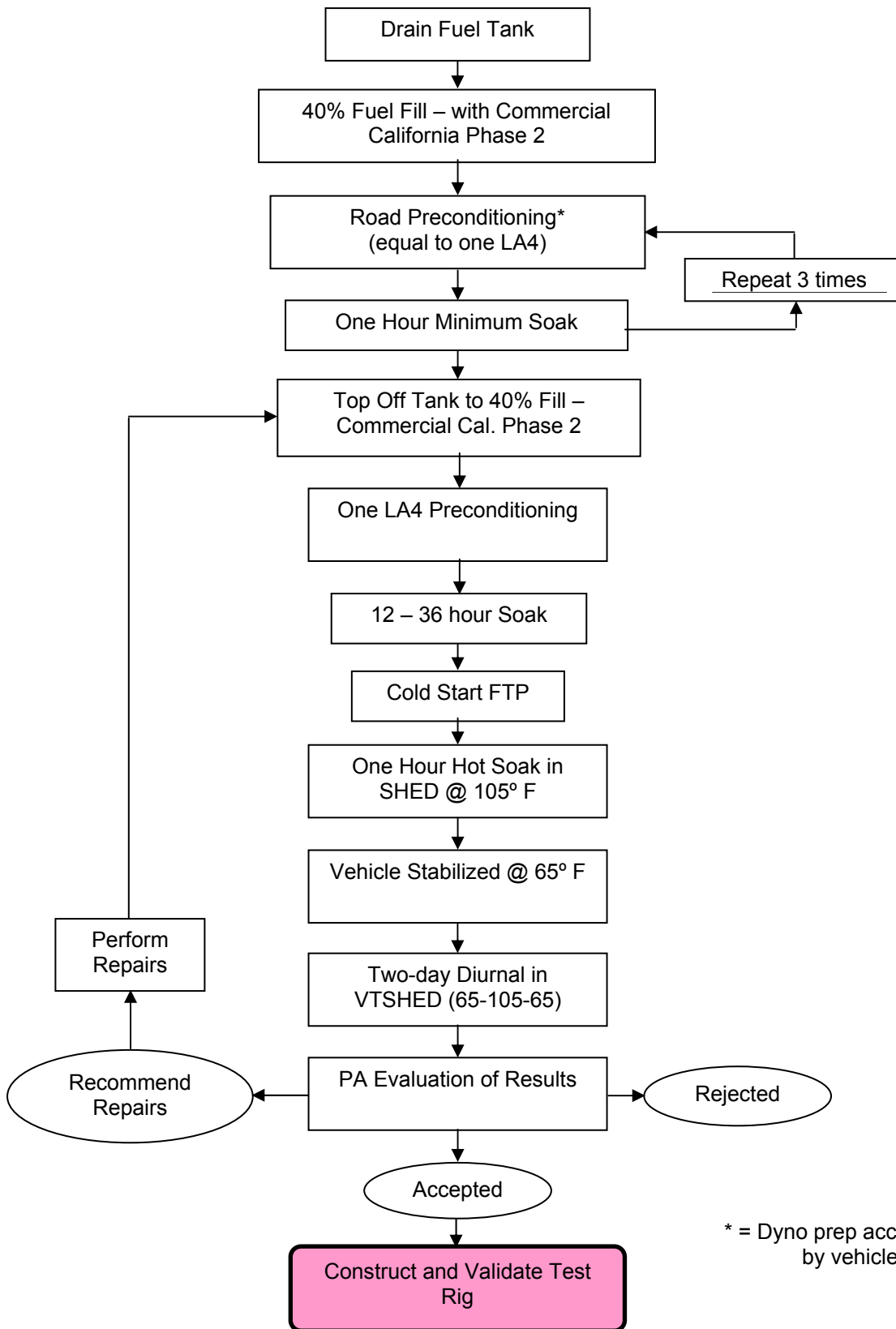

\* = Dyno prep acceptable if dictated by vehicle licensing

Chart 4  
Construct and Validate Test Rig

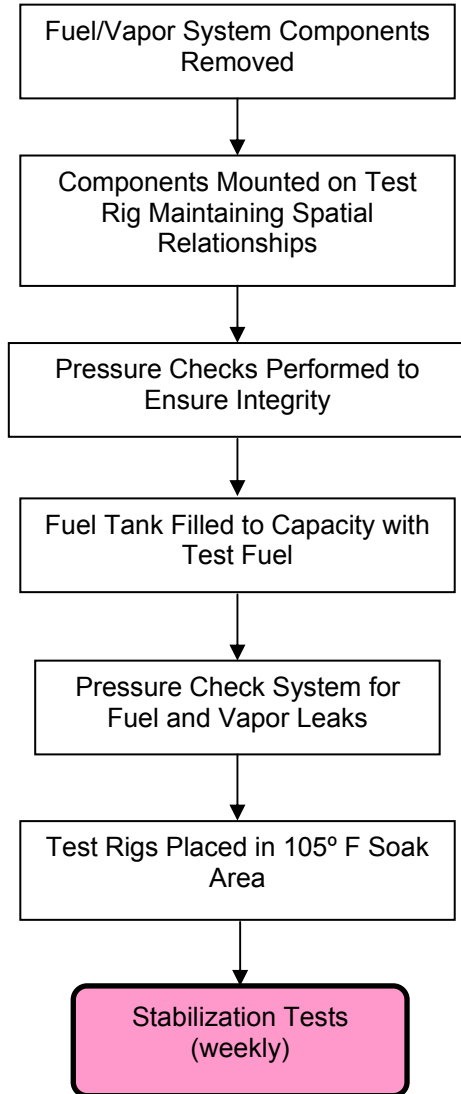

Typical Test Rig

Chart 5  
Test Fuel Change and Stabilization

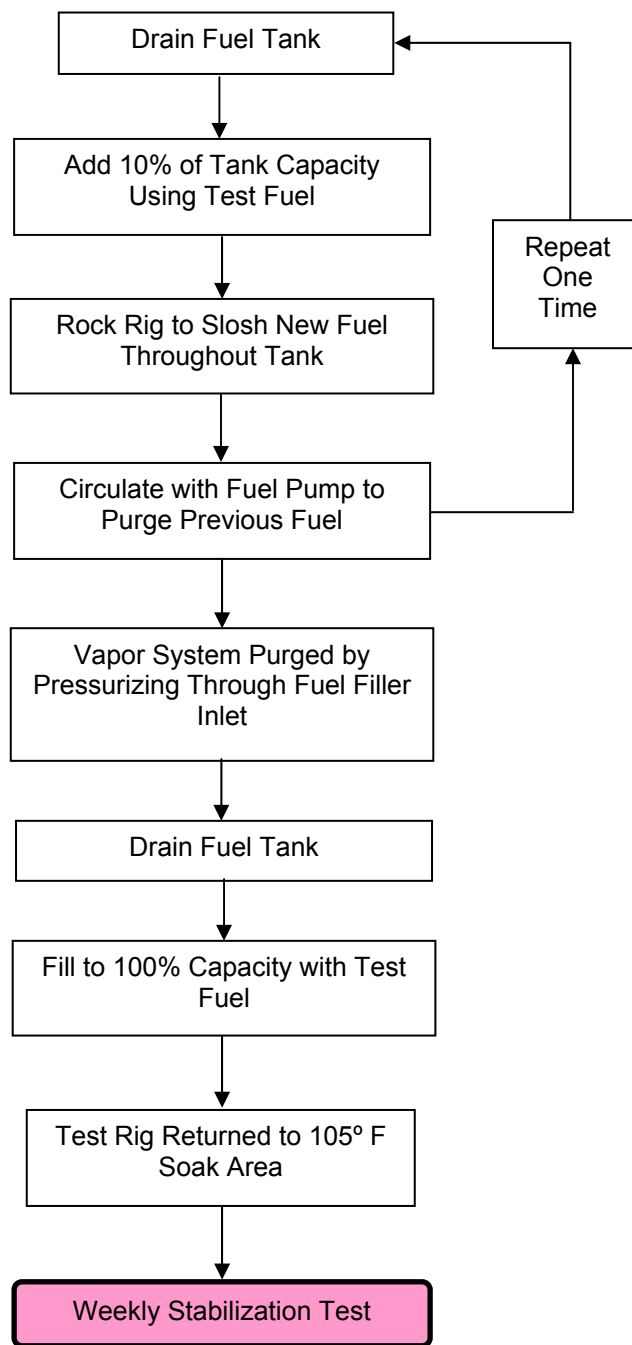

Chart 6  
Weekly Stabilization Test

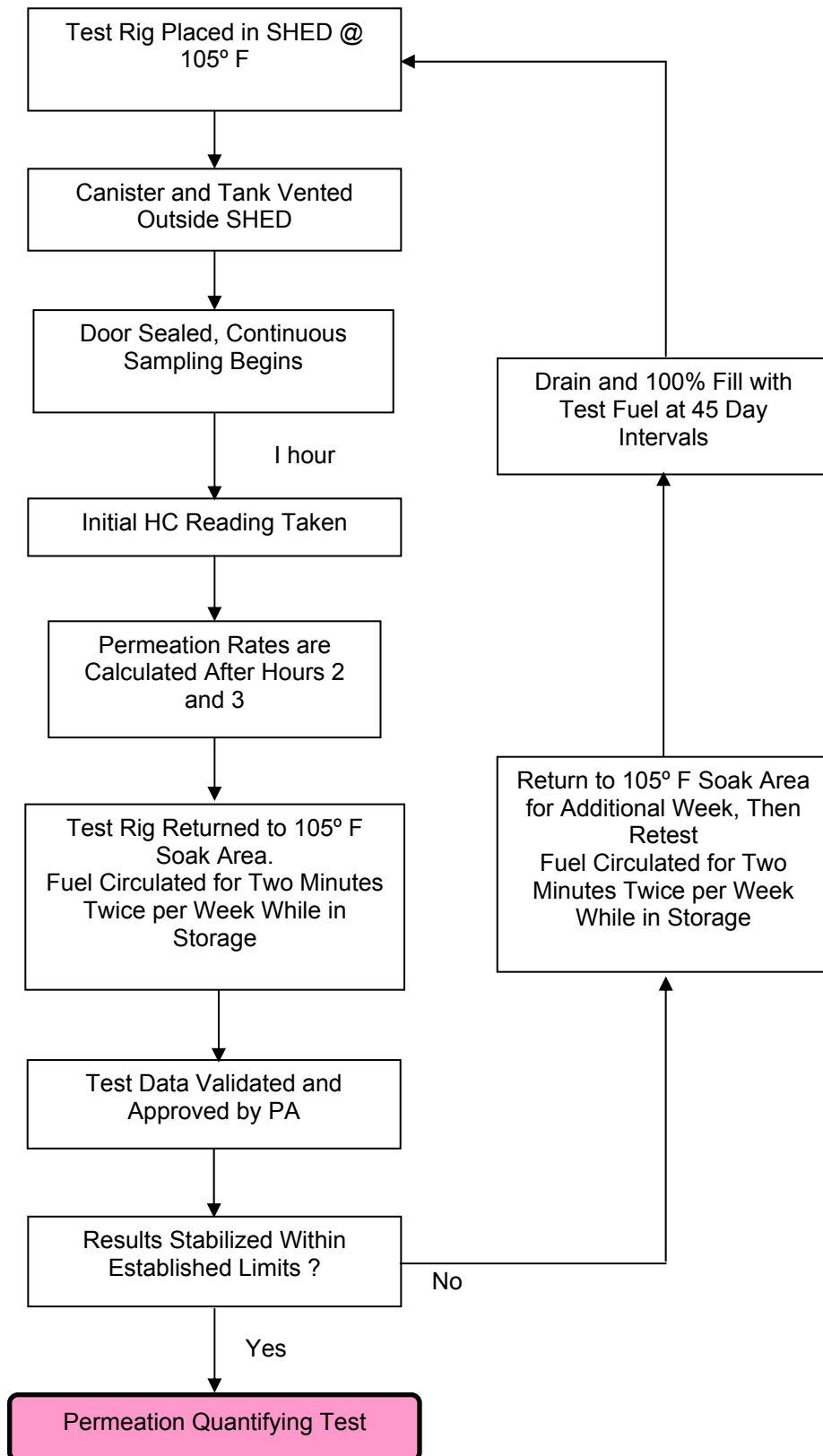

Chart 7  
Permeation Quantifying Test

Step 1 – Two Temperature Permeation Test

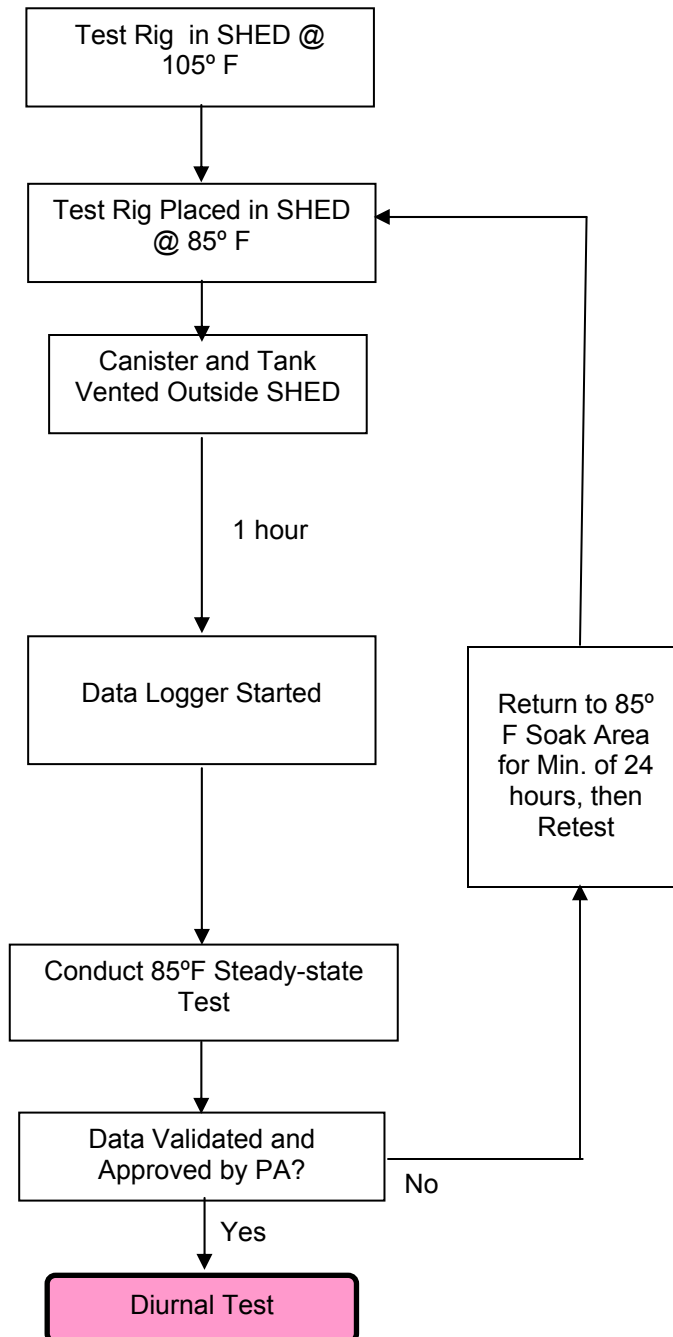
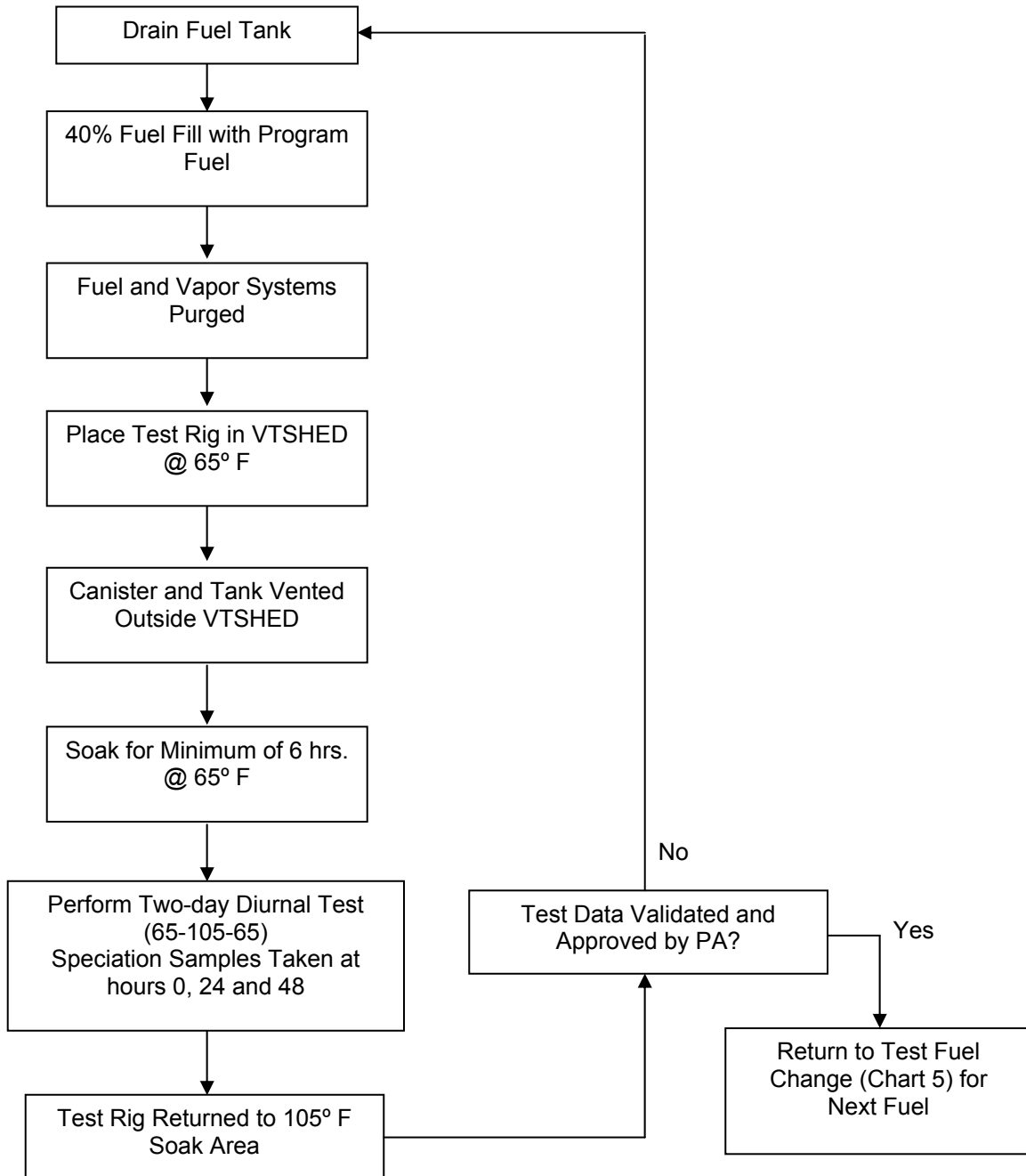

Chart 8  
Permeation Quantifying Test  
Step 2 - Diurnal Test



### Fleet Selection

A ten vehicle sample was selected to represent the range of light-duty vehicle technologies and ages that existed in the California in-use fleet in calendar year 2001. The sample size represented a pragmatic choice between manageability, cost, and a reasonable cross-section of vehicles.



Figure 1 – Vehicle Teardown

A 2001 summary of gasoline-fueled passenger cars and light-duty trucks registered in California was furnished by Mark Carlock, Chief, Mobile Source Analysis Branch, Planning and Technical Support Division, CARB. We divided the sorted list into 10 deciles, grouped by model year as shown in Figure 2. The oldest 10% were vehicles from the pre-1983 model year – more than 20 years old. The pre-1970 model year vehicles had no evaporative emission controls at all. The 1970 to 1980 models had only the simplest of controls – basically a carbon canister to contain the daily diurnal vapors.

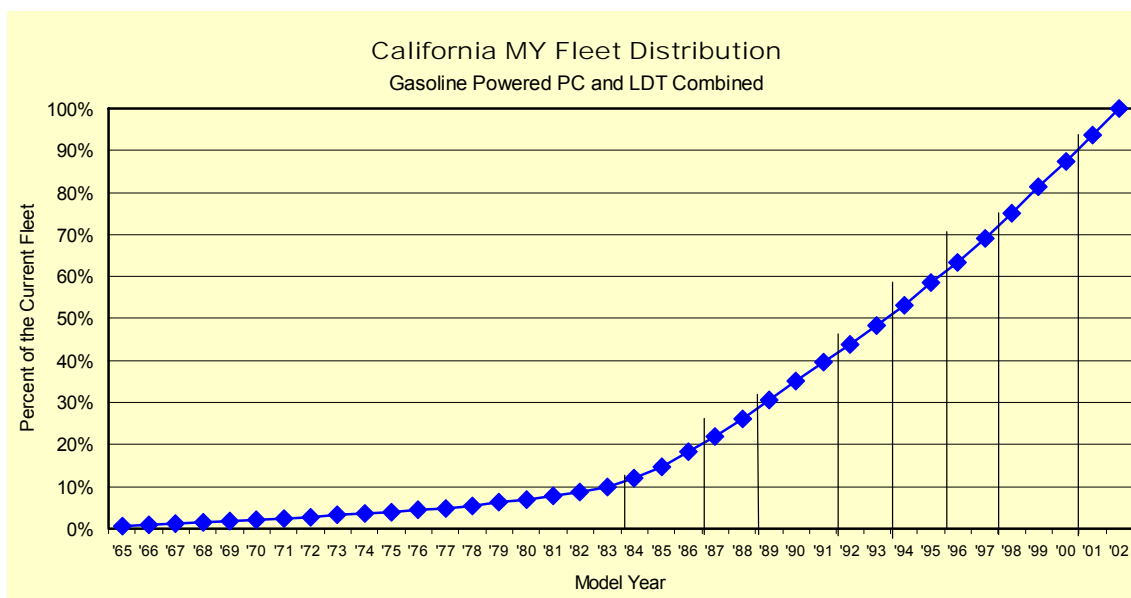

Figure 2

The project committee selected one vehicle from each of the model year decile groups. It was decided to balance the vehicle mix between cars, and light-duty trucks, which includes vans and sport utility vehicles. Choices were restricted to popular high-volume models that would be available in the existing population.

The test vehicle requirements were:

- Must be a California model from the California population
- Must have all the original evaporative control equipment present and functioning
- Must be in good mechanical condition, with no fuel system leaks

The final selection is listed in Table 1:

Table 1  
**E-65 Test Fleet Vehicles**

<b>Model Year</b>	<b>Vehicle Model</b>	<b>Rig No.</b>
2001	Toyota Tacoma (P/U)	1
2000	Honda Odyssey (Van)	2
1999	Toyota Corolla	3
1997	Chrysler Town and Country (Van)	4
1995	Ford Ranger (P/U)	5
1993	Chevrolet Caprice	6
1991	Honda Accord	7
1989	Ford Taurus	8
1985	Nissan Sentra	9
1978	Oldsmobile Cutlass	10

Six passenger cars and four trucks were chosen. Four vehicles had non-metallic fuel tanks – the Honda Odyssey (Rig 2), the Chrysler Town and Country (Rig 4), the Ford Ranger (Rig 5), and the Chevrolet Caprice (Rig 6). The significance of the tank material is that permeation is a function of surface area, and a fuel tank is the largest surface area component of the vehicle’s fuel and vapor system.

Rigs 1 through 8 were purchased from dealers -- 9 and 10 (the oldest vehicles) were purchased from private parties. Lab personnel traveled to inspect the vehicles to insure that they were suitable for the project. The newest 4 vehicles were driven from California to the Mesa, Arizona test facility, stopping at the California border to fill the tank with California conforming gasoline. The older vehicles (5 through 10) were trailered from California to the laboratory, again, filling with California fuel near the border to keep the permeation rate consistent with the California type fuel.

The odometers on the fleet ranged from 15,000 miles on the newest vehicle, the 2001 Toyota Tacoma, to 143,000 miles on the 1985 Nissan Sentra. Six vehicles had odometers over 100k miles. The oldest vehicle, the 1978 Oldsmobile Cutlass had 58k miles. Detailed test vehicle specifications are shown on Table 2.

Table 2  
**E-65 Fleet Specifications**

Veh				Engine Size	Fuel					Tank	40%	Plastic	Enhan.	
No.	Yr	Make/	Model	CID	L	Sys.	Odo.	Engine Family	Evap Family	Size	Fill	Metal	ORVR	VIN
							miles			gallons				
001	2001	Toyota	Tacoma	146	2.4	PFI	15,460	1TYXT02.4FFH	1TYXE0095AE0	15.8	6.3	Metal	Enh.	5TENL42N01Z718176
002	2000	Honda	Odyssey	214	3.5	PFI	119,495	YHNXT03.5EA3	YHNXE0130AAE	20.0	8.0	Plastic	Enh.	2HKRL1852YH518467
003	1999	Toyota	Corolla	110	1.8	PFI	77,788	XTYXV01.8DXB	XTYXR0115AK1	13.2	5.3	Metal	ORVR	1NXBR12EXXZ279565
004	1997	Chrysler	Tow n & Country	232	3.8	PFI	71,181	VCR23228G1EK	VCR1098AYP1A	20.0	8.0	Plastic	neither	1C4GP64L7VB367264
005	1995	Ford	Ranger	140	2.3	PFI	113,077	SFM2.318G1EK	SFM1045AYP0A	16.5	6.6	Plastic	neither	1FTCR14A6SPA11610
006	1993	Chevrolet	Caprice Classic	305	5.0	TBI	100,836	P1G5.7W5XEA9	PB0-1A	23.0	9.2	Plastic	neither	1G1BL53E9PR134928
007	1991	Honda	Accord LX	134	2.2	PFI	136,561	MHN2.2V5PC2	91FG	17.0	6.8	Metal	neither	JHMCB7659MC054984
008	1989	Ford	Taurus GL	182	3.0	PFI	110,623	KFM3.0V5FED8	9HM	16.0	6.4	Metal	neither	1FABP52U2KG140620
009	1985	Nissan	Sentra	98	1.6	Carb	142,987	FNS1.6V9FBC2	5ECC-3	13.2	5.3	Metal	neither	JN1PB15S3FU166896
010	1978	Olds.	Cutlass	262	4.3	Carb	58,324	830H2U	78BD	18.1	7.2	Metal	neither	3R47F8G439470

The vehicles represented by the three newest rigs, (1999 MY = Rig 3, 2000 MY = Rig 2, and 2001 MY = Rig 1), were all certified to the “enhanced” evaporative emission requirements (CA LEV) and were developed against a 24 hour<sup>6</sup> diurnal requirement. The evaporative emissions certification procedures used for the earlier model year vehicles represented in this study measured permeation during a 1 hour hot soak, and a “compressed-time” one hour diurnal. The enhanced test procedures put more emphasis on control of permeation in real-time.

Rig 4, the fuel system from a 1997 Chrysler Town and Country Van, was not certified to the “enhanced evap” standards, but clearly had advanced hardware fitted in anticipation of the upcoming regulations. This was verified by the DaimlerChrysler representative to the Steering Committee.

The 1993 MY Rig 6, and 1995 MY Rig 5 featured non-metallic fuel tanks of blow-molded high-density polyethylene construction. Rig 6 used a fluorination surface treatment on the inside of the tank to lower the permeation.

Each vehicle was given a complete inspection when it arrived at the lab to verify that all the emission components were present, and in good repair. The fuel system was pressure checked, and an engineering-type one-day diurnal test was performed to insure that the vehicle was suitable for the program. One vehicle was rejected after receipt at the lab, which required obtaining another candidate.

### **Test Rig Construction**

Fuel system test “rigs” are used in the automotive development process to isolate the fuel system’s contribution to the emissions. Since tires, adhesives, paint and vinyl trim can also emit hydrocarbons, they need to be removed to provide a better chance of properly identifying the fuel-related emissions. Isolating the fuel system components on a “rig” was the appropriate choice.

Refueling vapor controls are commonly developed in the automotive industry using rigs, or “test bucks”, but they feature only the tank and canister system, with the carbon canister located close to the tank. This project included the fuel and vapor lines, and their chassis to engine connection hoses at the front of the vehicle.

All the fuel system components that could contribute to permeation losses had to be kept in the original spatial relationship. This meant that the rigs were almost as long as the vehicles. For system integrity, all components were removed and remounted without any disconnections. The photo of Rig 9 in Figure 3 shows one of the results.

In all cases, the vehicle was sacrificed, and the remaining parts and pieces sold to a scrap dealer. The Caprice and the Cutlass were bodies-on-frame, and required significant effort with a power saw to cut away the frame to allow the fuel lines to come free. The test rig frame was constructed of 1.5” square aluminum tube, with metal caster wheels at the 4 corners. Additional photos of some of the components are shown in Figures 4 and 5.

---

<sup>6</sup> The vehicle is tested for up to three days in the SHED. The highest day’s value (24 hour period) is used to determine compliance with the standard.



Figure 3. Test Rig 9



Figure 4. Canister and Controls Mounting



Figure 5. Test Rig 4

A complete set of the rig photos is available at [www.arb.ca.gov/fuels/gasoline/gasoline.htm](http://www.arb.ca.gov/fuels/gasoline/gasoline.htm).

### **Fuel Properties**

The project required three matched fuels – two with 2 weight percent oxygen, and a matching non-oxygenated fuel. The fuels were called A, B and C, and were tested in the following order:

1. MTBE containing fuel (2 wt.% oxygen) (Fuel A)
2. Ethanol containing fuel (2 wt.% oxygen) (Fuel B)
3. Non-oxygenated fuel (Fuel C)

Commercial fuels expected to meet these requirements were obtained by ChevronTexaco from terminals and inspected, including detailed hydrocarbon analyses. Based on these inspections, adjustments were made. The three test fuels were prepared with volatilities matched to the extent possible. The parameters that were matched included, in order of importance, RVP, T10, T50, T90.

Fuel A was found to contain too much oxygen and was lower in toluene content than the other fuels. Therefore, toluene and isopentane were added to lower the oxygen content and increase the toluene content while maintaining the vapor pressure. Fuel B was found to be much lower in olefins content than the other fuels so light FCC naphtha was added. Ethanol was added to the adjusted blend to bring its oxygen content back to 2.0 wt %. Fuel B was obtained without the required deposit control additive. The same deposit control additive present in Fuels A and C was added to Fuel B at the same use concentration so there would be no deposit control additive difference among the fuels. No adjustments were made to Fuel C.

ChevronTexaco supplied complete chemical speciation results for the three fuels as liquids. A short summary of the speciations is presented in Table 3. The various HC species in Fuel A were ranked and tabulated by their weight % in the fuel. Fuel B and C species are aligned with the same species in Fuel A to allow a direct comparison of the composition of the three fuels. The complete speciation listings for the three liquid fuels are contained in a Microsoft Excel™ file on the companion CR-ROM as “Liquid Fuel Speciation.xls.”

A fuel acceptance panel consisting of four laboratories inspected the three test fuels. The average results of these inspections are shown in Table 4. The individual inspections obtained by each laboratory are shown in Appendix H. The same standard ASTM test methods were used by all laboratories. Distillation results were not provided by one laboratory because of analytical problems with the test method. The results indicate that the vapor pressures, 10% evaporated points, 50% evaporated points, and 90% evaporated points were matched to the extent possible while trying to keep the aromatics and olefins contents similar.

A summary analysis of the three test fuels classified by major hydrocarbon category and carbon number is shown in Table 5.

Table 3

**Liquid Fuel Speciation Comparison – Top 46 Components**

Fuel A Hydrocarbon Species Sorted by Weight % in the Liquid

Fuels B and C Components Aligned with Fuel A

	Fuel A	Fuel B	Fuel C
<u>Species</u>	<u>Wt.%</u>	<u>Wt.%</u>	<u>Wt.%</u>
<b><u>Oxygenates</u></b>			
MTBE	10.50	0.00	0.00
TAME	1.12	0.00	0.00
Ethanol	0.00	5.86	0.00
<b><u>Hydrocarbon Species</u></b>			
Toluene	9.61	8.06	9.98
2-methylbutane	9.07	6.64	10.86
2-methylpentane	4.42	5.21	6.98
m-Xylene	3.72	4.69	5.63
3-methylpentane	2.73	3.36	4.22
Pentane	2.69	2.23	3.84
Methylcyclopentane	2.54	2.84	3.39
124-TriMe-benzene	2.38	2.58	2.42
Hexane	2.00	1.66	2.59
o-Xylene	1.76	2.13	2.60
224-triMe-pentane	1.63	3.64	2.19
3-methylhexane	1.59	2.81	2.12
Methylcyclohexane	1.52	3.16	0.90
1-Me-3-Et-benzene	1.49	1.65	1.52
2-methylhexane	1.46	2.51	1.79
2,3-dimethylbutane	1.29	1.40	2.03
2,3-dimethylpentane	1.18	1.75	1.51
Ethylbenzene	1.18	1.42	1.84
Heptane	1.17	2.90	1.20
Cyclohexane	1.15	1.12	1.91
p-Xylene	1.14	1.45	1.53
2-Methylheptane	0.91	0.70	0.66
3-methylheptane	0.86	0.76	0.76
2,2-dimethylbutane	0.80	1.07	1.47
233-triMe-pentane	0.79	1.30	1.17
234-triMe-pentane	0.77	1.38	1.02
135-triMe-benzene	0.74	0.86	0.76
Butane	0.67	0.72	0.68
Octane	0.66	0.45	0.37
Benzene	0.64	0.86	0.85
1-Me-4-Et-benzene	0.61	0.73	0.66
1C3-diMecyclopentane	0.58	0.90	0.39
2,4-dimethylpentane	0.56	0.67	0.69
225-trimethylhexane	0.53	0.36	0.95
1-Me-2-Et-benzene	0.52	0.53	0.51
Propylbenzene	0.51	0.45	0.43

E65 Final Report - Fuel Permeation from Automotive Systems

1T3-diMecyclopentane	0.50	0.78	0.33
123-triMe-benzene	0.48	0.48	0.48
2-methyl-2-butene	0.48	0.54	0.47
1T2-diMecyclopentane	0.46	0.83	0.26
Cyclopentane	0.46	0.40	0.54
2-Me-3-Et-pentane	0.42	0.52	0.45
2,4-dimethylhexane	0.41	0.59	0.44
2,5-dimethylhexane	0.38	0.50	0.40
% of Fuel	81.1	85.5	85.8

The 5.86 weight percent concentration of ethanol corresponds to 2.0 weight percent oxygen in Fuel B.

Table 4

**CRC E-65 Permeation Study Fuel Inspections**

(Average of Four Laboratories)

Inspection	Units	Fuel A	Fuel B	Fuel C
		CARB 2 MTBE	CARB 3 Ethanol	CARB 2 Non-Oxy
API Gravity	°API	58.8	58.2	61.0
Relative Density	60/60°F	0.7437	0.7461	0.7352
DVPE	psi	7.05	7.12	7.03
Oxygenates--D 4815				
MTBE	vol%	9.88	<0.1	0.04
TAME	vol%	1.13	<0.1	0.02
EtOH	vol%	0.0	5.46	0.0
O2	wt%	1.98	2.02	0.01
FIAM Corrected--D 1319				
Aromatics	vol%	22.9	25.9	26.7
Olefins	vol%	5.0	5.8	6.0
Saturates	vol%	61.1	62.8	67.3
Oxygenates	vol%	11.0	5.46	0.07
Aromatics--D 5580				
Benzene	vol%	0.53	0.72	0.73
Toluene	vol%	8.26	6.90	8.46
Ethylbenzene	vol%	0.91	1.12	1.45
p/m-Xylene	vol%	3.82	4.91	5.71
o-Xylene	vol%	1.42	1.76	2.11
C9+	vol%	8.59	10.13	7.62
Total	vol%	24.26	26.24	27.20
D 86 Distillation*				
IBP	°F	100.7	108.5	101.0
5% Evaporated	°F	126.1	128.7	128.0
10% Evaporated	°F	135.8	133.8	136.3
20% Evaporated	°F	147.8	140.1	147.9
30% Evaporated	°F	160.7	155.4	160.4
40% Evaporated	°F	176.5	184.5	175.4
50% Evaporated	°F	195.7	202.8	193.1
60% Evaporated	°F	219.2	218.4	213.3
70% Evaporated	°F	243.7	235.8	236.3
80% Evaporated	°F	270.0	261.2	262.4
90% Evaporated	°F	308.8	304.0	297.9
95% Evaporated	°F	333.4	332.2	324.0
EP	°F	373.0	385.7	366.3
Recovery	vol%	97.4	98.1	97.9
Residue	vol%	1.4	1.0	0.9
Loss	vol%	1.2	0.9	1.2
Gum				
Unwashed	mg/100ml	16.8	19.1	18.5
Washed	mg/100ml	1.0	0.5	0.6
Sulfur	ppm	25.7	14.7	17.7

\* One lab did not provide inspections of this property.

Table 5

**CRC E-65 Permeation Study**  
**Test Fuel Detailed Hydrocarbon Analysis**

FUEL A -- CARB 2 MTBE - BY VOLUME% and CARBON NUMBER:

CARBON NUMBER	N-Paraffin	Iso-Paraffin	Olefins	Naphthas	Aromatics	Oxygenate	Un-Classified	Total Per Carbon
C3-	0.01							0.01
C4	0.86	0.10	0.05			0.01		1.02
C5	3.17	10.80	1.36	0.45		10.45		26.23
C6	2.23	10.36	1.55	3.59	0.54	1.07		19.34
C7	1.26	5.50	0.64	3.33	8.19			18.93
C8	0.69	7.00	0.53	2.12	6.63		0.01	16.99
C9	0.39	3.09		0.57	6.03		0.39	10.47
C10	0.17	1.43		0.21	2.80		0.57	5.17
C11	0.07	0.35			0.58		0.47	1.47
C12+	0.03	0.01			0.03		0.30	0.37
TOTAL	8.88	38.63	4.14	10.27	24.79	11.53	1.75	100.00

FUEL B -- CARB 3 ETHANOL - BY VOLUME% and CARBON NUMBER:

CARBON NUMBER	N-Paraffin	Iso-Paraffin	Olefins	Naphthas	Aromatics	Oxygenate	Un-Classified	Total Per Carbon
C3-			0.00			5.51		5.51
C4	0.92	0.15	0.01					1.08
C5	2.63	7.94	1.52	0.40		0.02		12.51
C6	1.87	12.44	2.34	3.88	0.73			21.25
C7	3.15	8.90	0.65	5.81	6.89			25.40
C8	0.47	10.57	0.27	0.97	8.28		0.01	20.58
C9	0.14	1.57	0.00	0.23	6.49		0.09	8.53
C10	0.04	0.44		0.03	3.04		0.14	3.69
C11	0.02	0.14			0.67		0.20	1.03
C12+	0.03	0.04			0.14		0.22	0.43
TOTAL	9.28	42.17	4.80	11.33	26.23	5.52	0.66	100.00

FUEL C -- CARB 2 NON-OXY - BY VOLUME% and CARBON NUMBER:

CARBON NUMBER	N-Paraffin	Iso-Paraffin	Olefins	Naphthas	Aromatics	Oxygenate	Un-Classified	Total Per Carbon
C3-	0.00							0.00
C4	0.85	0.08						0.93
C5	4.47	12.79	1.16	0.53		0.03		18.97
C6	2.86	16.32	2.78	5.10	0.71	0.01		27.78
C7	1.28	7.11	0.86	2.01	8.41			19.67
C8	0.38	7.94	0.33	1.00	9.77		0.01	19.43
C9	0.13	2.44	0.01	0.28	5.95		0.12	8.93
C10	0.05	0.61		0.07	2.20		0.21	3.13
C11	0.04	0.17			0.43		0.28	0.92
C12+	0.01	0.01			0.06		0.17	0.25
TOTAL	10.07	47.46	5.13	8.98	27.52	0.04	0.79	100.00

### Data Collection and Quality Control

Five issues are presented in this section: 1. The correction for ethanol, 2. The technique used to reduce the uncertainty around the steady-state measurement, 3. The definition of stability for the 105°F steady-state measurements, 4. The Quality Control Rig, and 5. Gas Chromatograph (GC) Speciation Procedure

**Correction for Ethanol in SHED Measurements** - Analyses of SHED samples in the E-65 program at ATL are based on the procedures detailed in the State of California ARB document: "California Non-Methane Organic Gas Test Procedures" as amended August 5, 1999.<sup>7</sup>

A standard Flame Ionization Detector (FID) exhibits different response rates for the different hydrocarbon species occurring in gasoline. These differences are considered to be minor, except for the underreporting on methanol and ethanol. Correction factors for this response rate were initially defined with respect to methanol and carried over to ethanol.

The SHED FID measures Total Hydrocarbon (THC). This reading is corrected with Fuel B by subtracting the ppm of ethanol measured by the gas chromatograph (GC). This corrected THC ppm is used to compute non-ethanol hydrocarbon mass emissions. The non-ethanol mass emissions of Fuel B can be compared to the non-ethanol mass emissions measured with Fuel A and Fuel C.

The ethanol ppm is used to compute the mass of ethanol emissions. The mass of the non-ethanol emissions is added to the mass of the ethanol emissions to arrive at the total emissions for the test.

Three values are reported for ethanol fuels: non-ethanol hydrocarbon emissions, ethanol emissions, and the sum, as shown in Table 6.

Table 6  
**Permeation Test Results**

Rig	Fuel	Week	Date	Test#	NonEtOH (g/hr)	EtOH (g/hr)	NonEtOH + EtOH (g/hr)	Running Average (g/hr)	Note
01	01 Toyota Tacoma		03/11/03	Drain and 100% fill fuel A					
	A	7	03/13/03	5086			0.0204	0.0203	
	A	8	03/20/03	5106			0.0094		85°
			03/24/03	Drain and 40% fill fuel A					
	A	D1*	03/25/03	5118			0.253		DHB
	A	D2*	03/26/03	5118			0.229		DHB
			04/09/03	Drain and 100% fill Fuel B					
	B	0	04/10/03	5162	0.0308	0.0053	0.0361		
	B	1	04/17/03	5186	0.0332	0.0248	0.0580		
	B	2	04/23/03	5207	0.0332	0.0232	0.0564		

- D1 and D2 denote Day 1 and Day 2 of the diurnal test. Results are in g/day units.

<sup>7</sup> CARB website: [www.arb.ca.gov/fuels/gasoline/gasoline.htm](http://www.arb.ca.gov/fuels/gasoline/gasoline.htm)

**Reducing Uncertainty in the Steady-State Measurements** - Emission test variation has been an historical concern. Something is measured twice with different values. Which one is right? The concern for variation becomes significant as the measurement levels decrease, perhaps approaching the level of detection. This was a subject of much study during the mid-70s when the exhaust emission standards were “drastically” lowered. (See SAE 770136, “A Treatise on Emission Test Variability”, by W. Juneja, et al)

The FIDs used in contemporary evaporative emission testing have a very high level of precision, i.e., the ability to resolve very small concentration differences (not to be confused with “accuracy”, a different issue).

The weekly tests were examined using an unusual technique developed by the project Steering Committee to gather the most repeatable data. It is described as follows:

The steady-state testing done at ATL for the E-65 project sampled (measured) the concentration in the SHED every 30 seconds, and with suitable precision to detect a reliable difference, established the emission rate for each half minute. The 30-second measurements were a “grab sample”, and 12 of these consecutive samples were averaged to make a six minute average. Ten 6-minute averages were then used to create an hourly permeation rate measurement with a higher level of confidence than simply measuring the concentration at time zero, and then again an hour later.

The procedure was as follows: The measurement SHED was stabilized at the test temperature. The rig was brought from the soak area to the SHED, placed in position, and the door closed and sealed. When the temperature in the SHED had returned to the test temperature and was stable, the 3-hour test started.

The steady-state permeation levels were measured on these rigs as was described in the plan of work, and the project flow charts, for 3 hours at 105°F. The SHED mass was sampled and reported every 30 seconds on the facility’s data logger. As mentioned above, 12 readings of the incremental 30-second mass-grams for a 6-minute period were measured and averaged to produce an hourly rate (g/hour).

The vertical scale is the permeation hourly rate. Each diamond represents the permeation hourly rate estimate for each 6 minute period. The first hour results shown in Figure 6 were not as stable as desired and were not used further. (See the discussion below regarding the decision to discontinue relying upon the first hour results for determining the weekly steady-state permeation levels.) Highlighted in red

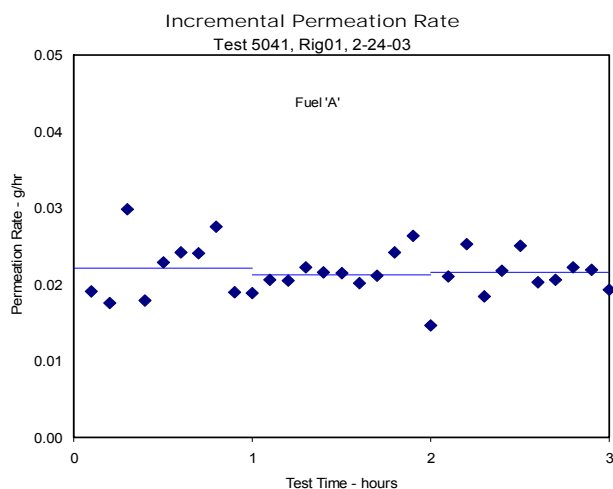

Figure 6

were any 6-minute readings that were more than 2 standard deviations from the hourly mean data on the plot. The measurement at 2 hours (red symbol) was outside the 2 standard deviations from the mean level in the analysis. The lab quality supervisor was alerted to a possible problem with the sample or analysis train, and corrective action was taken.

The 10 six minute averages for hour 2 were averaged to establish the average level for hour 2. Ninety % confidence interval estimates (n=10) for the hour 2 mean were calculated using the procedure from Microsoft Excel™. This procedure was repeated for the hour 3 data. Finally, the average of the 20 six minute estimates was used to determine a composite average for hours 2 plus 3.

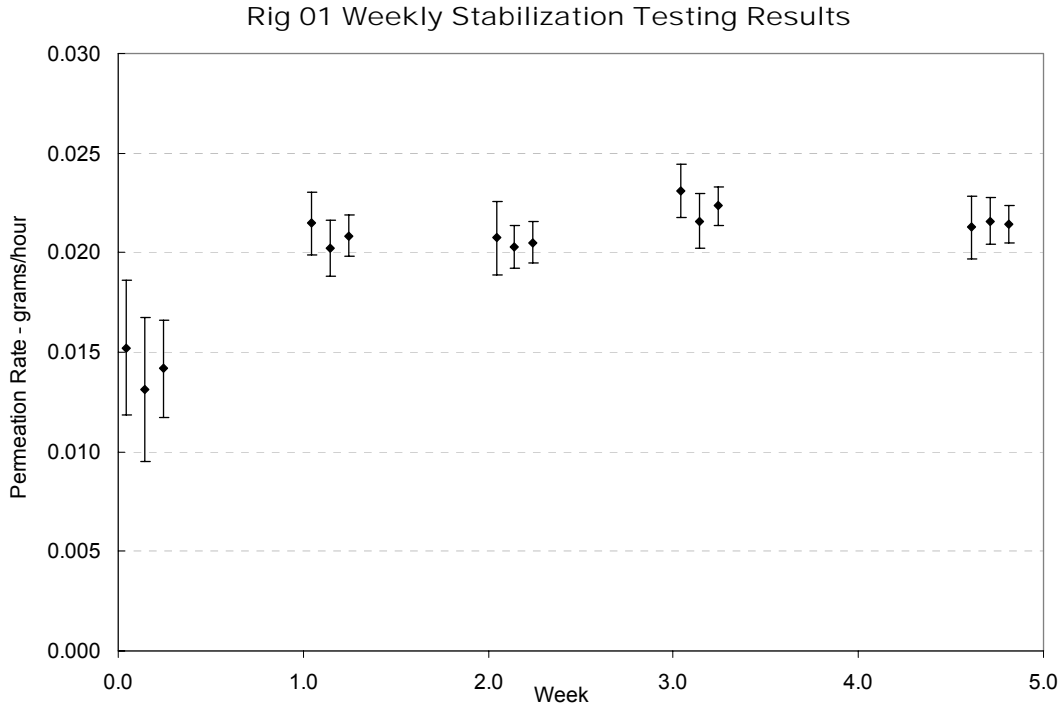

Figure 7

The plot shown in Figure 7 represents the type of data presentation first used for review and approval. For each week there were three estimates. The left most dot and whiskers represented the average and the 90% confidence limits for hour 2. The middle dot and whiskers are the values for hour 3, and the rightmost dot and whiskers are the values for the combined data (n=20) for hours 2 and 3.

It was expected that the data for hour 2 would not be different from hour 3. If a difference was detected, it might be a SHED or rig stability problem. After several months to build confidence, it was decided to discontinue the hour 2-hour 3 comparison, and present only the average value for the 20 measurements made during hours 2 and 3 as the weekly estimate of the permeation rate. The stability of the measurements was continually monitored, and the analysis saved in a lengthy summary called the “Section 3 Analysis.”

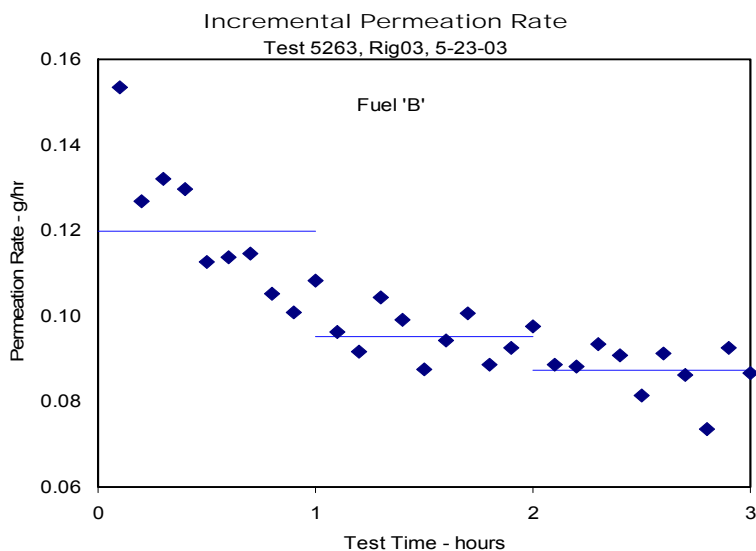

Figure 8

The plot shown in Figure 8 illustrates a condition that was sometimes observed, and led to a decision by the Steering Committee to not use the first hour measurements in the calculation of the weekly average steady-state permeation rate. The vertical scale is the measured emissions rate for each 6-minute sample, expressed in grams/hour. The horizontal scale is the official test period, three hours. An average value for each of the three hours of the test are indicated by the hour long horizontal lines in blue. The first hour average is indicated at 0.12 g/hour.

The trend indicated on the plot in Figure 8 shows a decreasing rate over time. The first hour was higher than later measurements in this example. Hours two and three were relatively stable.

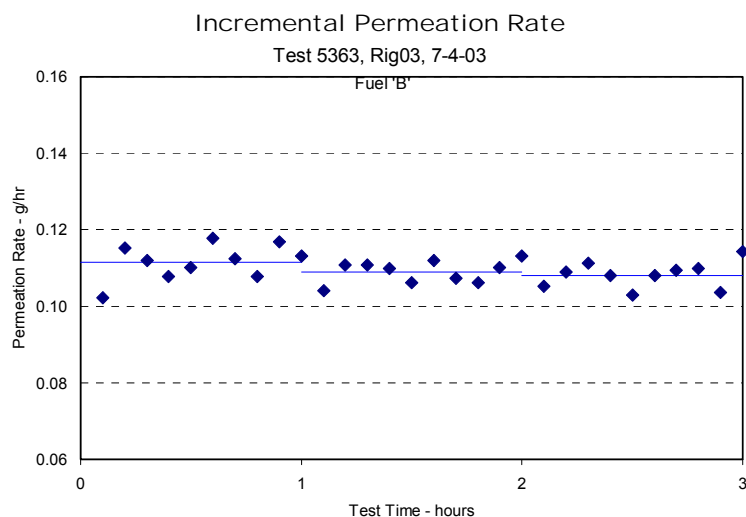

Figure 9

The plot shown in Figure 9 was more typical of the majority of the data. Hours one, two and three had permeation emission rates that were similar – this is what was expected.

**The First Hour Anomaly – A Theory** Regarding the issue illustrated in Figure 8, the SHED has a heating and cooling system for temperature control. When the SHED was opened to insert the rig, the temperature dropped below the set point. When the door is closed the heating system had to become active to re-establish the temperature. During this re-heating period, there may be some “baking off” of latent HC that had been previously trapped in the fins and crevices of the heat exchanger. This would give a higher initial rate of emissions, gradually returning to some stable value.

**Stabilization Technique** - Permeation is known to be strongly affected by temperature, and the results of this test program confirm that observation. It was decided to subject the rigs to a constant temperature (105°F), measuring the hourly permeation rate once a week (also at 105°F) until the permeation rate was deemed to be stabilized. The formal criteria for stabilization was a reversal in the 4 test moving average, modified somewhat by the Steering Committee’s judgment. An example is offered in Table 7 to explain the concept.

Table 7  
Permeation Test Results – Example

2000 Honda Odyssey											Trend	
Rig	Fuel	Week	Date	Test#	NonEtOH (g/hr)	EtOH (g/hr)	NonEtOH + EtOH (g/hr)	Stdev	Conf.	Running Average		
02	A		05/22/03	<u>Drain and 100% fill fuel A</u>								
		0	05/23/03	5264			0.0817	0.0064	0.0024			
		1	05/30/03	5276			0.0658	0.0040	0.0015			
		2	06/06/03	5293			0.0582	0.0031	0.0011			
		3	06/13/03	5309			0.0608	0.0025	0.0009	0.0666		
		4	06/20/03	5327			0.0668	0.0055	0.0020	0.0629	↓	
		5	06/27/03	5345			0.0532	0.0033	0.0012	0.0597	↓	
		6	07/04/03	5364			0.0563	0.0032	0.0012	0.0593	↓	
		7	07/11/03	5388			0.0513	0.0047	0.0017	0.0569	↓	
		8	07/18/03	5411			0.0510	0.0039	0.0014	0.0530	↓	
			07/24/03	<u>Drain and 100% fill Fuel A</u>								
		9	07/25/03	5433			0.0595	0.0062	0.0023	0.0545	↑	
		10	08/01/03	5456			0.0578	0.0087	0.0032	0.0549	↑	

Table 7 was selected from the Microsoft Excel™ file, “Rig Test Summary.xls,” which lists the test history for each rig on each fuel. The fuel tank was drained, and filled to 100% of rated capacity on 5/22. The rig was first tested the next day (Week 0), and each week thereafter. The test number is the internal laboratory test identifier. The next 2 columns were used in the later tests to identify the non-EtOH hydrocarbons, and the EtOH measured. The 8<sup>th</sup> column (NonEtOH + EtOH) is the total permeation rate in grams per hour for that weekly test. The 9<sup>th</sup> column is the standard deviation calculated from 20 six-minute permeation rate measurements (See the subsection in this report entitled “Reducing Uncertainty in the Steady-State Measurements.”). The next column is the 90% confidence interval on the average measurement, given the variation observed in the 20 six-minute observations of the SHED mass increase. The column labeled Running Average is the average of the 4 total permeation values (column 8) reported for the current and the immediately preceding 3 weeks. The final column indicates whether the 4-week running average has decreased or increased.

The average decreased each week from week 4 through week 8 when there was a scheduled fuel change on 7/24. The test on 7/25 replaced a low weekly measurement with a higher one, and the average increased comparable to the previous 4 week value, resulting in a trend reversal. There was concern that the 7/25 measurement was an artifact of the fuel change, and another test was requested. The test on 8/01 verified that the permeation had stabilized, and the rig was authorized for the performance test sequence. This technique is presented graphically in Figure 10.

Rig 2 Stabilization Testing

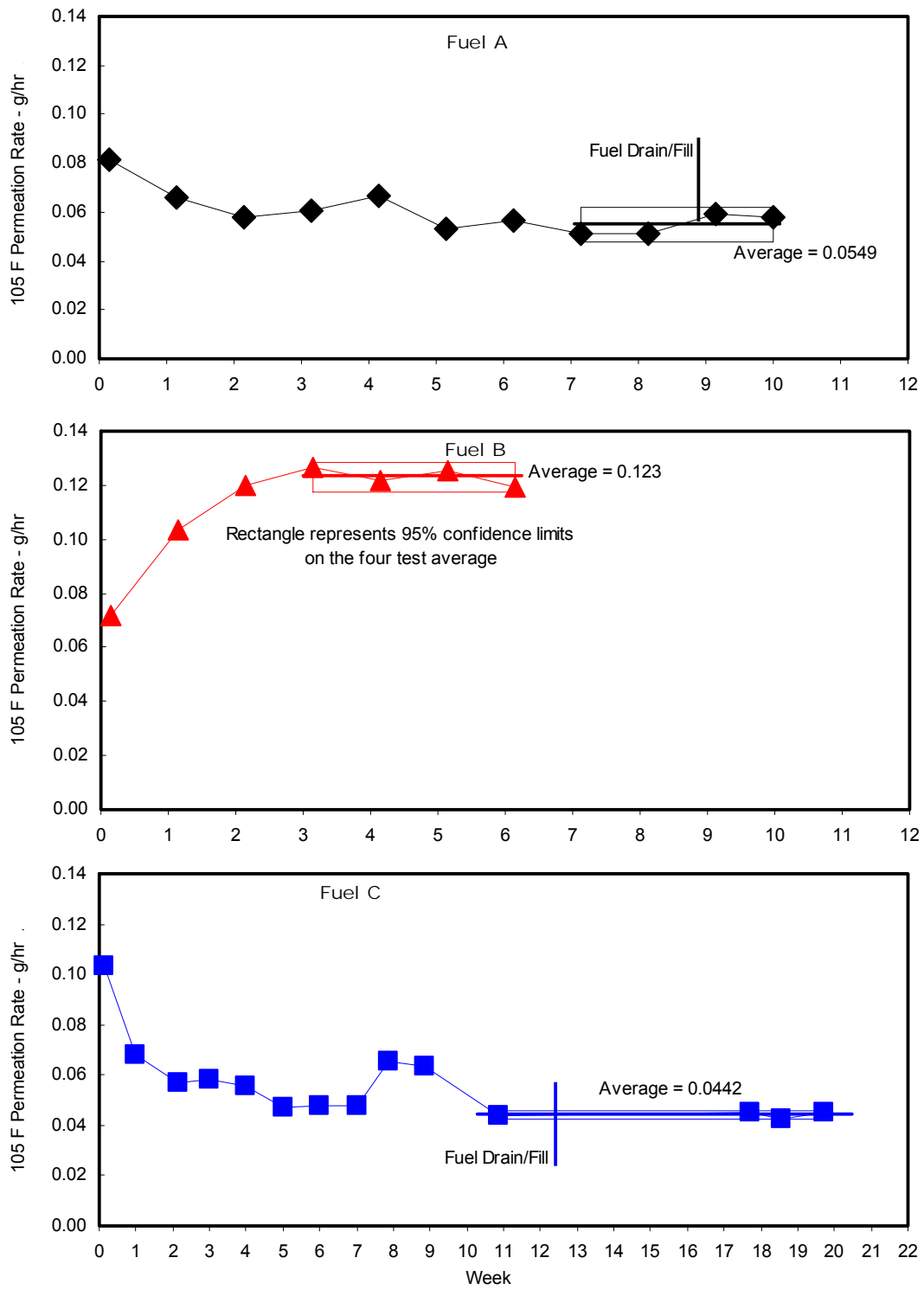

Figure 10

**The Quality Control Rig** - Previous experience had proved the value of a “repeatable” emission source as a quality check on the emission measurement system. Early in the project a “quality control rig” was fabricated using a 23-gallon capacity non-metallic fuel tank to perform this service. The fuel tank used was the same make and model as the one on Rig 6, the 1993 Chevrolet Caprice. The large capacity meant it would hold a lot of fuel, and have less sensitivity to “weathering” of the fuel, since periodic fuel changes were not planned.

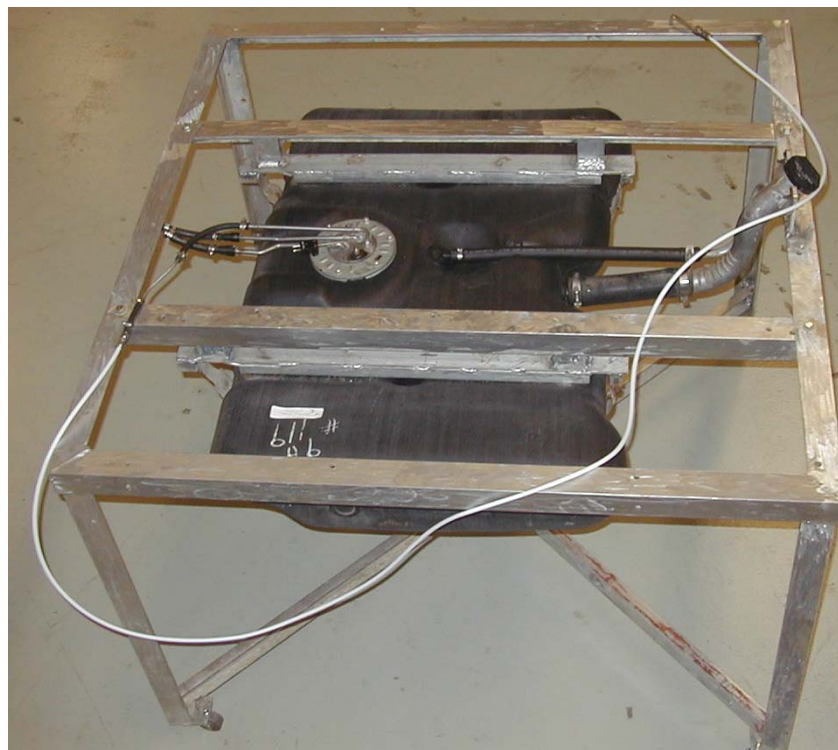

Figure 11. The QC Rig

A photo of the QC Rig appears in Figure 11. It consists of a HDPE 23-gallon fuel tank and fill pipe assembly, with short stub hoses on the fuel and vapor vent lines. The vapor space of the tank is vented outside the SHED during the permeation test measurement, as was done on the test rigs.

Figure 12 shows the weekly permeation rate measurements made on the QC Rig. The horizontal scale is the individual weekly measurements. Fifty-eight (58) weeks of the latest data are shown. The vertical scale (note the expanded scale used) is the hourly rate, roughly 0.3 g/hour. The dot represents the average value, and the “whiskers” show the 90% confidence estimate on the average value, based on the 20 six-minute values used to create the average value. A trend line was fitted to the plot using the Microsoft Excel™ routines. The fuel was not changed during this interval, and some weathering occurred. The level dropped about 0.05 grams per hour over the 58-week period, and this was considered an acceptable amount for our purposes.

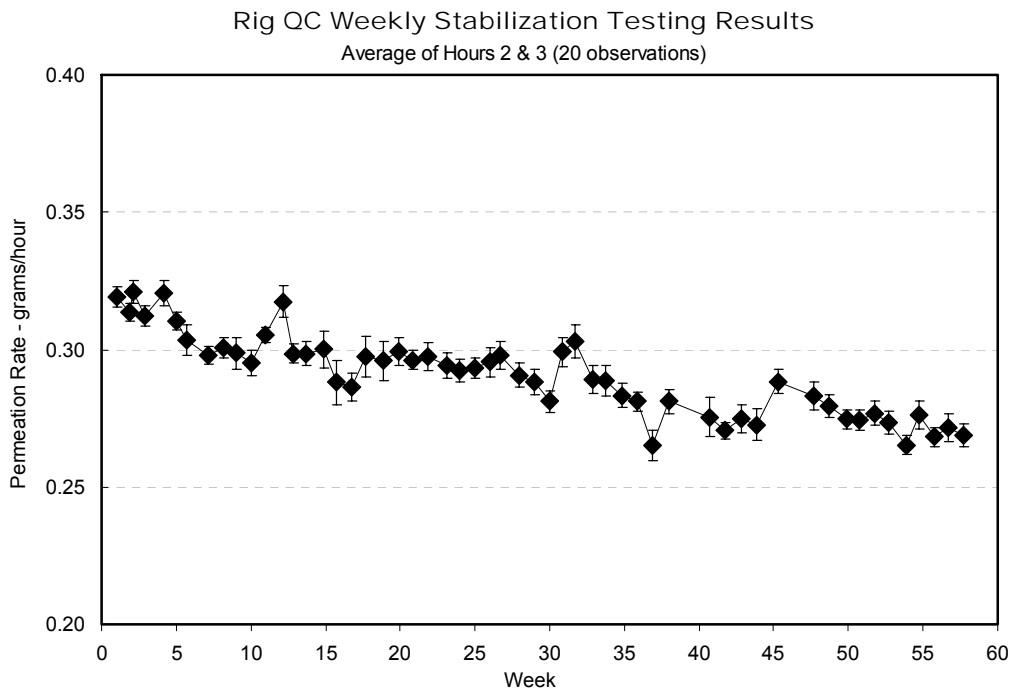

Figure 12

The 4 week running averages of the weekly permeation data for the QC Rig are shown in Figure 13.

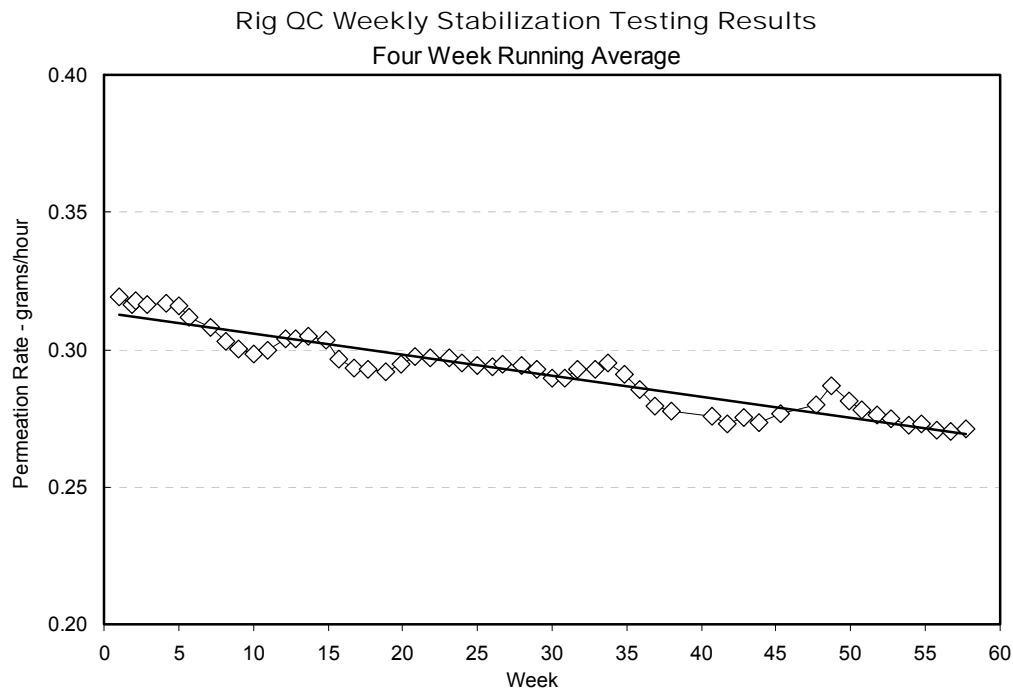

Figure 13

**Gas Chromatograph (GC) Speciation Procedure** - The testing laboratory (ATL) had developed a hydrocarbon speciation method that is functionally equivalent to, but possibly more efficient than, the dual-GC Auto-Oil Air Quality Improvement Research Program (AQIRP) method (no third column for benzene and toluene separations). This method has been used at ATL for much of its speciation. Instrumentation demands are simplified, and overall analysis time is shortened, yet high resolution and sensitivity are still achieved. In this single-GC method, all components are separated using one column type and temperature program. Analysis time for a cycle is 65 minutes. Each exhaust or evaporative gas sample is simultaneously injected (using a single sampling from the bag) into identical columns present in the dual column GC. Column A contains a 85  $\mu\text{l}$  sample loop (splitless injection) that provides an injection volume that is small enough to allow resolution of the C<sub>1</sub> through C<sub>4</sub> hydrocarbons while large enough to retain the highest sensitivity possible. Column B receives a 1000  $\mu\text{l}$  splitless injection, providing higher sensitivity for components eluting after isobutane. In both cases, the sample loop is controlled at column head pressure giving ambient pressure sample sizes of 195  $\mu\text{l}$  and 2000  $\mu\text{l}$  for the small and large injections, respectively. Quantitative comparison of three overlap components (butane, isopentane, and pentane) provides a quality control measure. Data from column A is used to detect and quantitate the 12 earliest eluting hydrocarbons (corresponding to the first 15 hydrocarbons listed in the SAE 930142 Hydrocarbon Speciation Library, minus t-2-butene, n-butane, and 2,2-dimethylpropane) with detection limits of 15-25 ppb C, corresponding to 0.2-0.3 mg/mi hydrocarbon for FTP stages 1 and 3, and 0.3-0.5 mg/mi for FTP stage 2. Data from column B gives detection limits of 0.017-0.04 mg/mi HC for components eluting after isopentane (18th in elution order). The components eluting between the 9th and 18th in elution order have detection limits ranging between the levels listed above for each column. In previous work which applied this analytical approach, detection limits were determined to be between 0.02 and 0.06 mg/mi for 1,3-butadiene and benzene. These detection limits can be compared to detection limits of 0.1 mg/mi (FTP composite) using the SAE 930142/AQIRP method. Benzene is sufficiently resolved from 1-methylcyclopentene using this method with no significant interferences; this is an advantage of ATL's method over the AQIRP method, which does not resolve this important pair in the C<sub>4</sub>-C<sub>12</sub> method. ATL's chromatographic conditions have been optimized to resolve these two species to a ratio of about 1:20, 1-methylcyclopentene:benzene. Thus, ATL's method gives an expected accuracy for benzene of 95% or greater.

## **Results**

The original test program, (105°F stabilization, 85°F steady-state test, and a 2-day 65-105-65°F diurnal test) was completed in late May of 2004. Hydrocarbon speciation was specified in the original task and the results were later augmented with the inclusion of maximum incremental ozone reactivity (MIR) values drawn from the literature. Two additional assignments (replicate diurnal tests on Fuel C, and a sensitivity test with reduced fill on the non-metallic tanks) were completed in July of 2004.

The results from these test components (on the three test fuels) are presented in the following order:

- Stabilization at 105°F
- Diurnal Measurements
- Speciation of the Diurnal SHED Vapors
- Reactivity Calculations
- The Increase in Non-Ethanol Hydrocarbon with Fuel B
- Steady-state Test Results - 105°F and 85°F
- Estimate of Experimental Variation
- Fill Level Comparison -- 100% vs. 20% Preconditioning on Fuel C

**Stabilization at 105°F** - Figure 14 on the next two pages displays the stabilization results for all three test fuels on all ten rigs. As a reminder, Fuel A is the MTBE blend, Fuel B is the ethanol blend and Fuel C is the non-oxygenated blend

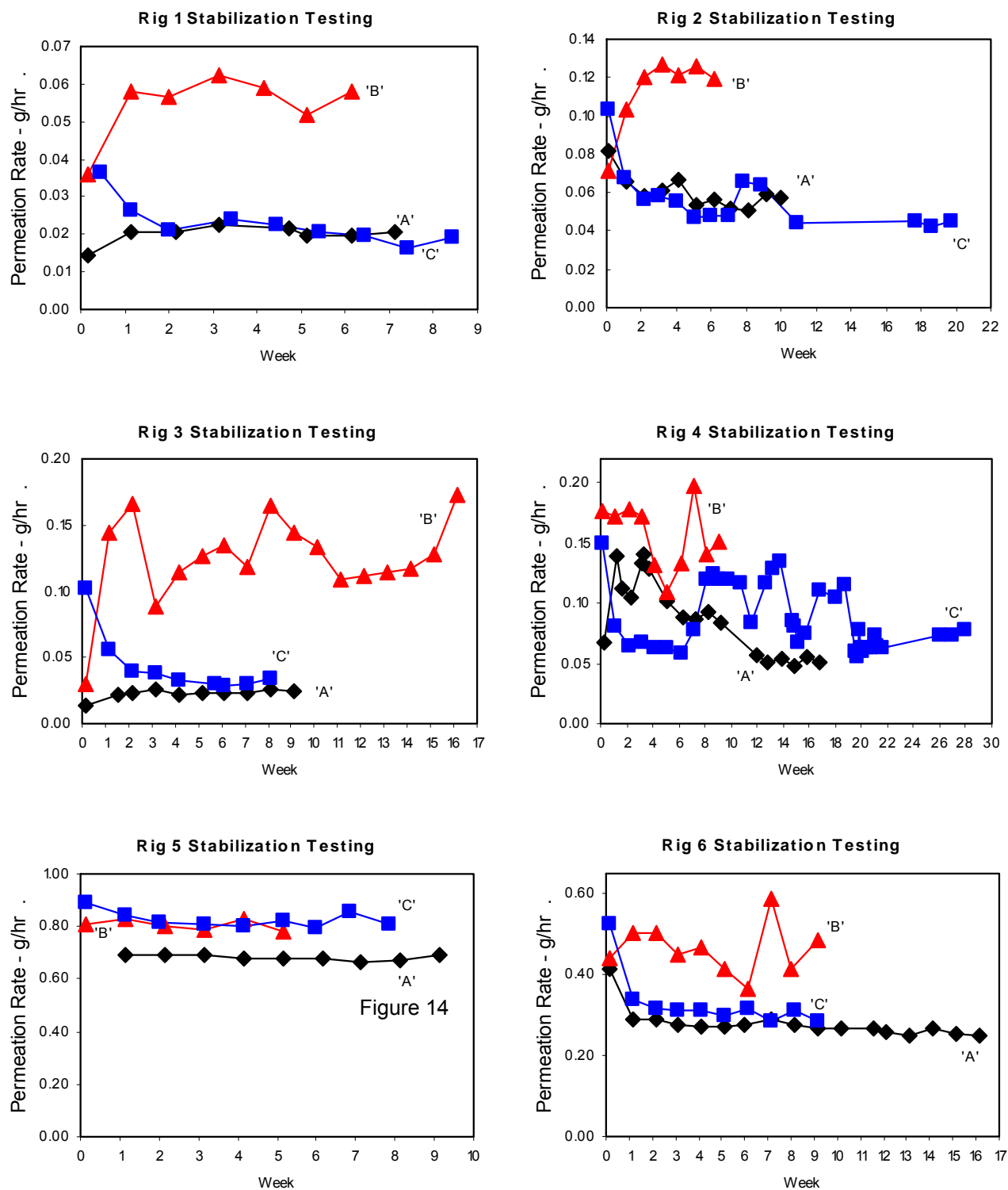

Figure 14

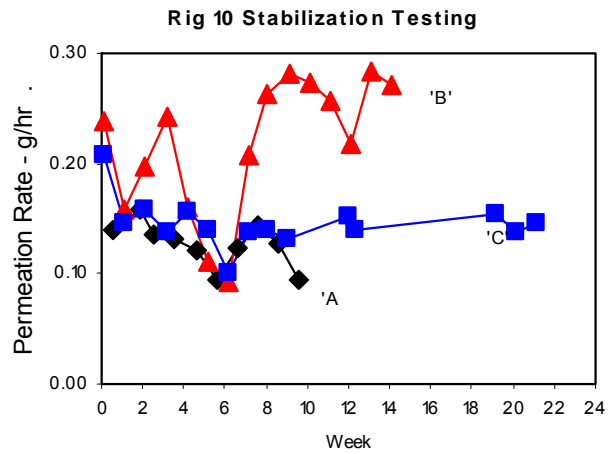
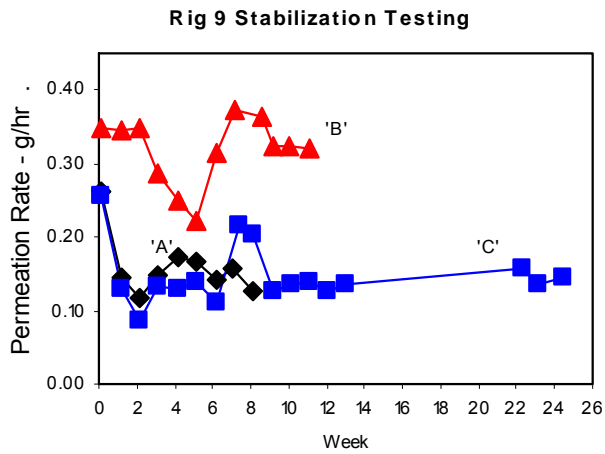
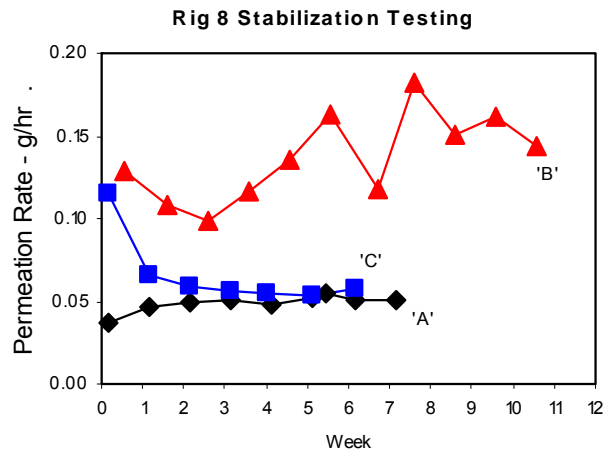
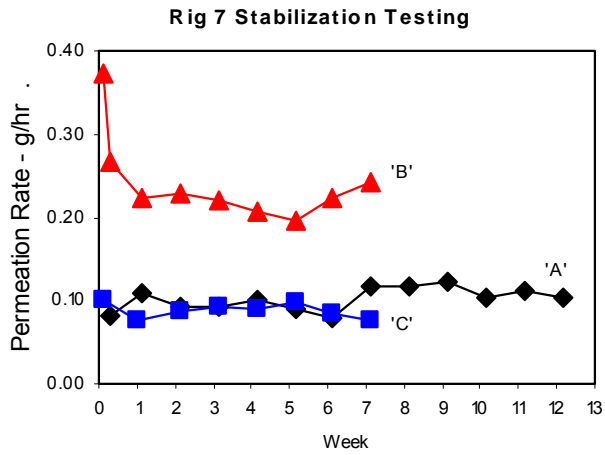

Figure 14 (Cont.)

**Diurnal Measurements** – Table 8 shows the average diurnal permeation results for the ten rigs on the three test fuels after stabilization at 105°F. All values are the average of days 1 and 2, and where multiple valid tests are available, all the data were used.

Table 8  
Average Diurnal Values

Rig	Vehicle	Tank	Average Emissions - g/day		
			Fuel A	Fuel B	Fuel C
1	2001 Toyota Tacoma	15.8 gal - Metal	0.24	0.76	0.22
2	2000 Honda Odyssey	20.0 gal - Plastic	0.64	1.43	0.58
3	1999 Toyota Corolla	13.2 gal - Metal	0.29	1.37	0.33
4	1997 Chrysler Town & Country	20.0 gal - Plastic	0.63	2.25	1.13
5	1995 Ford Ranger	16.5 gal - Plastic	9.20	11.65	11.75
6	1993 Chevrolet Caprice Classic	23.0 gal - Plastic	4.55	4.89	3.55
7	1991 Honda Accord LX	17.0 gal - Metal	1.24	2.25	1.91
8	1989 Ford Taurus GL	16.0 gal - Metal	0.96	2.63	0.82
9	1985 Nissan Sentra	13.2 gal - Metal	1.96	4.67	1.77
10	1978 Olds Cutlass Supreme	18.1 gal - Metal	1.92	3.74	2.44
Average			2.16	3.56	2.45

The behavior of Rig 5 on Fuel C is anomalous in that it is the only rig in which the permeation emissions on Fuel C were similar to those on Fuel B. Exhaustive checks of Rig 5's fuel system were performed, but no cause for the anomalous behavior could be identified. The data were considered valid and included in subsequent analyses.

Plots of the diurnal permeation results are shown in Figure 15. The horizontal axis is the model year of the test rigs. The vertical lines are the model year breaks for the deciles in the in-use California fleet. The vertical scale is the test results measured in the SHED in grams per day.

Looking at the left most test results (1978 – Rig 10), the green bar represents the average diurnal on Fuel A (1.92 g/day). The red bar is the representation of the Fuel B results (3.74 g/day). The blue bar is the Fuel C test results (2.44 g/day). Each rig is represented by a similar set of three colored bars.

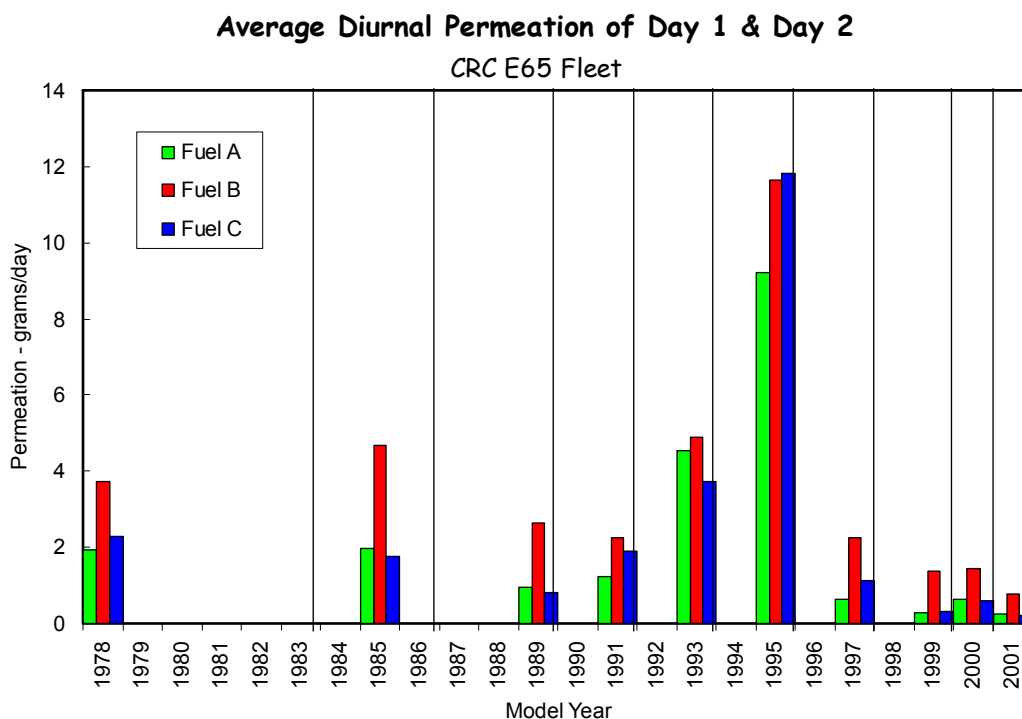

Figure 15

**Speciation Results (Diurnal)** - Each rig was tested for at least two days using the California diurnal test procedure, on each of the three test fuels. A sample of the enclosure’s ambient HC concentration was collected from the VT-SHED at the start and the end of each day in a Tedlar™ bag and later analyzed using a Varian™ chromatograph. The net mass change in the enclosure was computed for each of the two diurnal days.

An example of the speciation results for Rig 1 – Fuel A, days 1 & 2 is shown in Table 9. The complete speciation results are available on the companion CD ROM. Please note that the 48 hour results are the net cumulative increase for the two days. Results for day 2 can be calculated by subtracting the 24 hour (day 1) mass from the 48 hour results (day 1 + 2).

Rig: 01a  
Test#: 5118

Table 9.  
Speciation Results

<u>Detailed Hydrocarbon Speciation Results</u>			24 Hour				48 Hour			
			Net mass	Net conc.	% total		Net mass	Net conc.	% total	
Species Name	CAS #	(mg)	(ppmC)	(mg)	(ppmC)	(mg)	(ppmC)	(mg)	(ppmC)	
1	Methane	00074-82-8	0.549	0.014	0%	0%	1.618	0.044	0%	0%
2	Ethylene	00074-85-1	0.000	0.000	0%	0%	0.000	0.000	0%	0%
3	Acetylene (Ethyne)	00074-86-2	0.000	0.000	0%	0%	0.000	0.000	0%	0%
4	Ethane	00074-84-0	0.000	0.000	0%	0%	0.000	0.000	0%	0%
5	Propene	00115-07-1	0.000	0.000	0%	0%	0.000	0.000	0%	0%
6	Propane	00074-98-6	0.000	0.000	0%	0%	1.396	0.043	0%	0%
7	Allene (Propadiene)	00463-49-0	0.000	0.000	0%	0%	0.000	0.000	0%	0%
8	Propyne	00074-99-7	0.000	0.000	0%	0%	0.000	0.000	0%	0%
9	2-Methylpropane	00075-28-5	0.694	0.022	0%	0%	1.382	0.043	0%	0%
10.1	2-Methylpropene	00115-11-7	0.246	0.008	0%	0%	0.418	0.013	0%	0%
10.2	1-Butene	00106-98-9	0.130	0.004	0%	0%	0.222	0.007	0%	0%
11	1,3-Butadiene	00106-99-0	0.000	0.000	0%	0%	0.000	0.000	0%	0%
12	n-Butane	00106-97-8	6.863	0.213	3%	3%	13.262	0.412	3%	3%
13	2,2-Dimethylpropane	00463-82-1	0.000	0.000	0%	0%	0.000	0.000	0%	0%
14	t-2-Butene	00624-64-6	0.432	0.014	0%	0%	3.039	0.098	1%	1%
15	1-Butyne	00107-00-6	0.682	0.023	0%	0%	0.000	0.000	0%	0%
16	c-2-Butene	00590-18-1	0.180	0.006	0%	0%	0.346	0.011	0%	0%
17	3-Methyl-1-butene	00563-45-1	0.639	0.021	0%	0%	1.746	0.056	0%	0%
18	2-Methylbutane (Isopentane)	00078-78-4	32.940	1.031	14%	14%	64.662	2.024	14%	14%
19.1	1-Pentene	00109-67-1	0.217	0.007	0%	0%	0.870	0.029	0%	0%
19.2	2-Butyne	00503-17-3	0.000	0.000	0%	0%	0.000	0.000	0%	0%
20	2-Methyl-1-butene	00563-46-2	0.672	0.022	0%	0%	1.533	0.049	0%	0%
21	n-Pentane	00109-66-0	10.984	0.344	5%	5%	21.906	0.686	5%	5%
22	2-Methyl-1,3-butadiene	00078-79-5	0.000	0.000	0%	0%	0.131	0.004	0%	0%
23	t-2-Pentene	00646-04-8	1.558	0.050	1%	1%	3.084	0.099	1%	1%
24	3,3-Dimethyl-1-butene	00558-37-2	0.000	0.000	0%	0%	0.000	0.000	0%	0%
25	c-2-Pentene	00627-20-3	0.637	0.021	0%	0%	1.422	0.046	0%	0%
26	2-Methyl-2-butene	00513-35-9	2.808	0.090	1%	1%	5.560	0.179	1%	1%
27	Unknown #1		0.000	0.000	0%	0%	0.000	0.000	0%	0%
28	Cyclopentadiene	00542-92-7	0.000	0.000	0%	0%	0.000	0.000	0%	0%
29	2,2-Dimethylbutane	00075-83-2	1.199	0.038	0%	0%	2.400	0.075	1%	1%
30	Cyclopentene	00142-29-0	0.446	0.015	0%	0%	0.764	0.025	0%	0%
31.1	4-methyl-1-pentene	00691-37-2	0.000	0.000	0%	0%	0.329	0.011	0%	0%
31.2	3-methyl-1-pentene	00760-20-3	0.000	0.000	0%	0%	0.000	0.000	0%	0%
32	Cyclopentane	00287-92-3	0.000	0.000	0%	0%	0.000	0.000	0%	0%
33	MTBE	01634-04-4	33.333	0.843	14%	11%	65.317	1.652	14%	11%
34	2,3-Dimethylbutane	00079-29-8	4.089	0.116	2%	2%	8.012	0.227	2%	2%
34.1	2,3dimethyl-1-butene	00563-78-0	0.000	0.000	0%	0%	0.000	0.000	0%	0%
35	Unknown #2		0.000	0.000	0%	0%	0.000	0.000	0%	0%
36.1	2-MePentane	00107-83-5	9.176	0.289	4%	4%	17.942	0.565	4%	4%
36.2	4-Me-c-2-Pentene	00691-38-3	0.049	0.002	0%	0%	0.097	0.003	0%	0%
37	4-Methyl-t-2-pentene	00674-76-0	0.000	0.000	0%	0%	0.000	0.000	0%	0%
38	3-Methylpentane	00096-14-0	5.285	0.166	2%	2%	10.294	0.324	2%	2%
39.1	2-Methyl-1-pentene	00763-29-1	0.335	0.011	0%	0%	0.581	0.019	0%	0%
39.2	1-Hexene	00592-41-6	0.147	0.005	0%	0%	0.256	0.008	0%	0%
40	n-Hexane	00110-54-3	5.789	0.182	2%	2%	11.173	0.352	2%	2%
41.1	t-3-Hexene	13269-52-8	0.000	0.000	0%	0%	0.000	0.000	0%	0%
41.2	c-3-Hexene	07642-09-3	0.000	0.000	0%	0%	0.000	0.000	0%	0%
42	t-2-Hexene	04050-45-7	0.465	0.015	0%	0%	0.739	0.024	0%	0%
43	3-Methyl-t-2-pentene	00616-12-6	0.552	0.018	0%	0%	0.892	0.029	0%	0%
44	2-Methyl-2-pentene	00625-27-4	0.585	0.019	0%	0%	0.783	0.025	0%	0%

Rig: 01a  
Test#: 5118

Table 9 (cont).  
Speciation Results

<u>Detailed Hydrocarbon Speciation Results</u>			24 Hour				48 Hour			
			Net mass	Net conc.	% total		Net mass	Net conc.	% total	
Species Name	CAS #	(mg)	(ppmC)	(mg)	(ppmC)	(mg)	(ppmC)	(mg)	(ppmC)	
45.1	c-2-Hexene	07688-21-3	0.232	0.008	0%	0%	0.314	0.011	0%	0%
45.2	3-MeCyclopentene	01120-62-3	0.122	0.004	0%	0%	0.166	0.005	0%	0%
46	ETBE	00637-92-3	0.000	0.000	0%	0%	0.000	0.000	0%	0%
47	3-Methyl-c-2-pentene	00922-62-3	0.695	0.022	0%	0%	0.976	0.031	0%	0%
48	2,2-Dimethylpentane	00590-35-2	0.457	0.014	0%	0%	0.486	0.015	0%	0%
49	Methylcyclopentane	00096-37-7	5.738	0.185	2%	2%	10.877	0.350	2%	2%
50	2,4-Dimethylpentane	00108-08-7	1.321	0.042	1%	1%	2.379	0.075	1%	1%
51	2,2,3-Trimethylbutane	00464-06-2	0.408	0.013	0%	0%	0.454	0.014	0%	0%
52	1-Methylcyclopentene	00693-89-0	0.239	0.008	0%	0%	0.229	0.008	0%	0%
53	Benzene	00071-43-2	6.424	0.223	3%	3%	11.928	0.414	3%	3%
54	3,3-Dimethylpentane	00562-49-2	0.232	0.007	0%	0%	0.303	0.010	0%	0%
55	3-Me-1-Hexene	03404-61-3	0.269	0.009	0%	0%	0.314	0.010	0%	0%
56	Cyclohexane	00110-82-7	2.459	0.079	1%	1%	4.606	0.148	1%	1%
57	2-Methylhexane	00591-76-4	2.488	0.078	1%	1%	4.567	0.144	1%	1%
58	2,3-Dimethylpentane	00565-59-3	1.456	0.046	1%	1%	2.694	0.085	1%	1%
59.1	Cyclohexene	00110-83-8	0.000	0.000	0%	0%	0.000	0.000	0%	0%
59.2	3-Methylhexane	00589-34-4	2.495	0.079	1%	1%	4.793	0.151	1%	1%
60	Unknown #3		0.196	0.006	0%	0%	0.390	0.013	0%	0%
61	c-1,3-Dimethylcyclopentane	02532-58-3	0.813	0.026	0%	0%	1.620	0.052	0%	0%
62	t-1,2-Dimethylcyclopentane	00822-50-4	1.146	0.037	0%	0%	2.110	0.068	0%	0%
63	2,2,4-TriMePentane (IsoOctane)	00540-84-1	3.976	0.126	2%	2%	7.534	0.238	2%	2%
64	1-Heptene	00592-76-7	0.000	0.000	0%	0%	0.254	0.008	0%	0%
65	t-3-Heptene	14686-14-7	0.000	0.000	0%	0%	0.231	0.007	0%	0%
66	n-Heptane	00142-82-5	1.771	0.056	1%	1%	3.317	0.105	1%	1%
67.1	2-Methyl-2-Hexene	02738-19-4	0.395	0.013	0%	0%	0.982	0.032	0%	0%
67.2	c-3-Heptene	07642-10-6	0.000	0.000	0%	0%	0.000	0.000	0%	0%
68.1	3-Me-t-3-Hexene	03899-36-3	0.000	0.000	0%	0%	0.000	0.000	0%	0%
68.2	t-2-Heptene	14686-13-6	0.000	0.000	0%	0%	0.000	0.000	0%	0%
69	3-Ethyl-c-2-Pentene	00816-79-5	0.000	0.000	0%	0%	0.531	0.017	0%	0%
70.1	2,4,4-Trimethylpentene	00107-39-1	0.000	0.000	0%	0%	0.000	0.000	0%	0%
70.2	2,3-diMe-2-pentene	10574-37-5	0.151	0.005	0%	0%	0.394	0.013	0%	0%
71	c-2-Heptene	06443-92-1	0.244	0.008	0%	0%	1.033	0.033	0%	0%
72	Unknown #4		0.000	0.000	0%	0%	0.000	0.000	0%	0%
73	2,2-DiMeHexane	00590-73-8	0.000	0.000	0%	0%	0.000	0.000	0%	0%
74	Methylcyclohexane	00108-87-2	1.614	0.052	1%	1%	4.048	0.130	1%	1%
75	2,4,4-Trimethyl-2-Pentene	00107-40-4	0.207	0.007	0%	0%	0.204	0.007	0%	0%
76.1	2,5-DiMeHexane	00592-13-2	0.208	0.007	0%	0%	0.565	0.019	0%	0%
76.2	EtCyPentane	01640-89-7	0.200	0.006	0%	0%	0.542	0.016	0%	0%
77	2,4-Dimethylhexane	00589-43-5	1.093	0.035	0%	0%	2.166	0.069	0%	0%
78	3,3-Dimethylhexane	00563-16-6	0.300	0.009	0%	0%	0.673	0.021	0%	0%
79	2,3,4-Trimethylpentane	00565-75-3	1.140	0.036	0%	0%	2.312	0.073	0%	0%
80	2,3,3-Trimethylpentane	00560-21-4	0.000	0.000	0%	0%	0.000	0.000	0%	0%
81	Toluene	00108-88-3	47.503	1.630	20%	21%	91.075	3.125	19%	21%
82.1	2,3-dimethylhexane	00584-94-1	0.000	0.000	0%	0%	0.000	0.000	0%	0%
82.2	2-Me-3-Et-pentane	00609-26-7	0.481	0.015	0%	0%	0.680	0.022	0%	0%
83	2-Methylheptane	00592-27-8	0.737	0.023	0%	0%	1.130	0.036	0%	0%
84.1	1-MeCyHexene	00591-49-1	0.000	0.000	0%	0%	0.000	0.000	0%	0%
84.2	4-MeHeptane	00589-53-7	0.411	0.013	0%	0%	0.522	0.017	0%	0%
85	Unknown #5		0.000	0.000	0%	0%	0.238	0.008	0%	0%
86	3-Methylheptane	00589-81-1	0.554	0.018	0%	0%	1.256	0.040	0%	0%
87	1c-2t-3-TriMeCyPentane	15890-40-1	0.000	0.000	0%	0%	0.000	0.000	0%	0%

Rig: 01a  
Test#: 5118

Table 9 (cont).  
Speciation Results

<u>Detailed Hydrocarbon Speciation Results</u>			24 Hour				48 Hour			
			Net mass	Net conc.	% total		Net mass	Net conc.	% total	
Species Name	CAS #	(mg)	(ppmC)	(mg)	(ppmC)	(mg)	(ppmC)	(mg)	(ppmC)	
88	c-1,3-Dimethylcyclohexane	00638-04-0	0.452	0.015	0%	0%	0.729	0.023	0%	0%
89	t-1,4-Dimethylcyclohexane	02207-04-7	0.000	0.000	0%	0%	0.297	0.010	0%	0%
90	2,2,5-Trimethylhexane	03522-94-9	0.547	0.017	0%	0%	0.720	0.023	0%	0%
91	1-Octene	00111-66-0	0.000	0.000	0%	0%	0.000	0.000	0%	0%
92	1,1-Dimethylcyclohexane	00590-66-9	0.283	0.009	0%	0%	0.425	0.014	0%	0%
93	Unknown #6	.	0.114	0.004	0%	0%	0.310	0.010	0%	0%
94	t-4-Octene	14850-23-8	0.000	0.000	0%	0%	0.216	0.007	0%	0%
95	Unknown #7		0.000	0.000	0%	0%	0.000	0.000	0%	0%
96	n-Octane	00111-65-9	0.391	0.012	0%	0%	0.942	0.030	0%	0%
97.1	t-2-Octene	13389-42-9	0.000	0.000	0%	0%	0.000	0.000	0%	0%
97.2	t-1,2-DiMeCyHexane	06876-23-9	0.000	0.000	0%	0%	0.000	0.000	0%	0%
98.1	t-1,3	02207-03-6	0.381	0.012	0%	0%	0.591	0.019	0%	0%
98.2	c-1,4-DiMeCyHexane	00624-29-3	0.000	0.000	0%	0%	0.000	0.000	0%	0%
99	c-2-Octene	07642-04-8	0.000	0.000	0%	0%	0.000	0.000	0%	0%
100	2,3,5-Trimethylhexane	01069-53-0	0.301	0.010	0%	0%	0.561	0.018	0%	0%
101	2,4-Dimethylheptane	02213-23-2	0.192	0.006	0%	0%	0.192	0.006	0%	0%
102	Unknown #8		0.159	0.005	0%	0%	0.124	0.004	0%	0%
103	c-1,2-Dimethylcyclohexane	02207-01-4	0.000	0.000	0%	0%	0.000	0.000	0%	0%
104	Ethylcyclohexane	01678-91-7	0.719	0.023	0%	0%	0.892	0.029	0%	0%
105	3,5-Dimethylheptane	00926-82-9	0.000	0.000	0%	0%	0.000	0.000	0%	0%
106	Unknown #9		0.000	0.000	0%	0%	0.183	0.006	0%	0%
107	Unknown #10		0.000	0.000	0%	0%	0.327	0.011	0%	0%
108	Unknown #11		0.000	0.000	0%	0%	0.000	0.000	0%	0%
109	Ethylbenzene	00100-41-4	3.575	0.122	1%	2%	6.813	0.232	1%	2%
110.1	2,3-DiMeHeptane	03074-71-3	0.000	0.000	0%	0%	0.000	0.000	0%	0%
110.2	2-MeOctane	03221-61-2	0.000	0.000	0%	0%	0.000	0.000	0%	0%
111.1	m-Xylene	00108-38-3	11.739	0.399	5%	5%	22.337	0.759	5%	5%
111.2	p-Xylene	00106-42-3	3.600	0.123	1%	2%	6.850	0.234	1%	2%
112	4-Methyloctane	02216-34-4	0.542	0.017	0%	0%	0.622	0.020	0%	0%
113	3-Methyloctane	02216-33-3	0.310	0.010	0%	0%	0.311	0.010	0%	0%
114	Unknown #12		0.000	0.000	0%	0%	0.000	0.000	0%	0%
115	Styrene	00100-42-5	0.061	0.002	0%	0%	0.209	0.007	0%	0%
116	Unknown #13		0.000	0.000	0%	0%	0.000	0.000	0%	0%
117	ortho-Xylene	00095-47-6	1.690	0.057	1%	1%	3.821	0.130	1%	1%
118	1-Nonene	00124-11-8	0.000	0.000	0%	0%	0.000	0.000	0%	0%
119	c- & t-4-Nonene	02198-23-4	0.000	0.000	0%	0%	0.000	0.000	0%	0%
120	n-Nonane	00111-84-2	0.000	0.000	0%	0%	0.000	0.000	0%	0%
121	t-2-Nonene	06434-78-2	0.000	0.000	0%	0%	0.000	0.000	0%	0%
122	Isopropylbenzene (Cumene)	00098-82-8	0.000	0.000	0%	0%	0.228	0.008	0%	0%
123	2,2-Dimethyloctane	15869-87-1	0.000	0.000	0%	0%	0.000	0.000	0%	0%
124	Unknown #14		0.000	0.000	0%	0%	0.000	0.000	0%	0%
125.1	2,4-DiMeOctane	04032-94-4	0.000	0.000	0%	0%	0.000	0.000	0%	0%
125.2	AlBenz	00300-57-2	0.000	0.000	0%	0%	0.000	0.000	0%	0%
125.3	PrCyHexane	01678-92-8	0.000	0.000	0%	0%	0.000	0.000	0%	0%
126	Unknown #15		0.000	0.000	0%	0%	0.000	0.000	0%	0%
127	n-Propylbenzene	00103-65-1	0.534	0.018	0%	0%	1.083	0.037	0%	0%
128	1-Methyl-3-Ethylbenzene	00620-14-4	1.853	0.063	1%	1%	3.304	0.112	1%	1%
129	1-Methyl-4-Ethylbenzene	00622-96-8	0.908	0.031	0%	0%	1.518	0.051	0%	0%
130	1,3,5-Trimethylbenzene	00108-67-8	1.144	0.039	0%	1%	1.333	0.045	0%	0%
131	Unknown #16		0.000	0.000	0%	0%	0.000	0.000	0%	0%
132	Unknown #17		0.000	0.000	0%	0%	0.000	0.000	0%	0%

Rig: 01a  
Test#: 5118

Table 9 (cont).  
Speciation Results

<u>Detailed Hydrocarbon Speciation Results</u>		24 Hour				48 Hour				
		Net mass (mg)	Net conc. (ppmC)	% total (mg) (ppmC)		Net mass (mg)	Net conc. (ppmC)	% total (mg) (ppmC)		
133	1-Ethyl-2-Methylbenzene	00611-14-3	0.513	0.017	0%	0%	1.150	0.039	0%	0%
134	3-Methylnonane		0.000	0.000	0%	0%	0.000	0.000	0%	0%
135.1	1,2,4-TriMeBenz	00095-63-6	0.000	0.000	0%	0%	0.000	0.000	0%	0%
135.2	t-Butylbenzene	00098-06-6	0.000	0.000	0%	0%	0.000	0.000	0%	0%
136	n-Decane	00124-18-5	0.000	0.000	0%	0%	0.000	0.000	0%	0%
137	Isobutylbenzene	00538-93-2	0.000	0.000	0%	0%	0.000	0.000	0%	0%
138	sec-Butylbenzene	00135-98-8	0.000	0.000	0%	0%	0.000	0.000	0%	0%
139	1-Methyl-4-Isobutylbenzene	05161-04-6	0.622	0.021	0%	0%	0.000	0.000	0%	0%
140	1,2,3-Trimethylbenzene	00526-73-8	0.000	0.000	0%	0%	0.842	0.028	0%	0%
141	4-Isopropyltoluene (p-Cymene)	00099-87-6	0.000	0.000	0%	0%	0.000	0.000	0%	0%
142	Indan	00496-11-7	0.403	0.014	0%	0%	0.847	0.029	0%	0%
143	1,3-Diethylbenzene	00141-93-5	0.278	0.009	0%	0%	0.000	0.000	0%	0%
144	1-Methyl-3-Propylbenzene	01074-43-7	0.000	0.000	0%	0%	0.471	0.016	0%	0%
145	1,4-Diethylbenzene	00105-05-5	0.449	0.015	0%	0%	0.664	0.022	0%	0%
146	1,2-Diethylbenzene	00135-01-3	0.000	0.000	0%	0%	0.000	0.000	0%	0%
147	n-Butylbenzene	00104-51-8	0.000	0.000	0%	0%	0.000	0.000	0%	0%
148	1-Methyl-2-Propylbenzene	01074-17-5	0.000	0.000	0%	0%	0.000	0.000	0%	0%
149	1,4-Dimethyl-2-Ethylbenzene	01758-88-9	0.000	0.000	0%	0%	0.292	0.010	0%	0%
150	1,3-Dimethyl-4-Ethylbenzene	00874-41-9	0.000	0.000	0%	0%	0.267	0.009	0%	0%
151	1,2-Dimethyl-4-Ethylbenzene	00934-80-5	0.190	0.006	0%	0%	0.195	0.007	0%	0%
152	1,3-Dimethyl-2-Ethylbenzene	02870-04-4	0.000	0.000	0%	0%	0.000	0.000	0%	0%
153	1-Undecene	00821-95-4	0.000	0.000	0%	0%	0.000	0.000	0%	0%
154	n-Undecane	01120-21-4	0.000	0.000	0%	0%	0.000	0.000	0%	0%
155	Unknown #18		0.000	0.000	0%	0%	0.000	0.000	0%	0%
156	Unknown #19		0.000	0.000	0%	0%	0.000	0.000	0%	0%
157	1,2,4,5-Tetramethylbenzene	00095-93-2	0.000	0.000	0%	0%	0.000	0.000	0%	0%
158	1,2,3,5-Tetramethylbenzene	00527-53-7	0.000	0.000	0%	0%	0.000	0.000	0%	0%
159	Unknown #20		0.000	0.000	0%	0%	0.000	0.000	0%	0%
160	Unknown #21		0.000	0.000	0%	0%	0.000	0.000	0%	0%
161	Methylindan	27133-93-3	0.000	0.000	0%	0%	0.000	0.000	0%	0%
162	1,3-Diisopropylbenzene	00099-62-7	0.000	0.000	0%	0%	0.000	0.000	0%	0%
163.1	1,2,3,4-TetMeBenzene	00488-23-3	0.000	0.000	0%	0%	0.000	0.000	0%	0%
163.2	Amylbenz	00538-68-1	0.000	0.000	0%	0%	0.000	0.000	0%	0%
164	Unknown #22		0.000	0.000	0%	0%	0.000	0.000	0%	0%
165	Unknown #23		0.000	0.000	0%	0%	0.000	0.000	0%	0%
166	1,4-Diisopropylbenzene	00100-18-5	0.000	0.000	0%	0%	0.000	0.000	0%	0%
167	Unknown #24		0.000	0.000	0%	0%	0.000	0.000	0%	0%
168	Naphthalene	00091-20-3	0.000	0.000	0%	0%	0.000	0.000	0%	0%
169	1-Dodecene	00112-41-4	0.000	0.000	0%	0%	0.000	0.000	0%	0%
170	Unknown #25		0.000	0.000	0%	0%	0.000	0.000	0%	0%
171	Unknown #26		0.000	0.000	0%	0%	0.000	0.000	0%	0%
172	n-Dodecane	00112-40-3	0.000	0.000	0%	0%	0.000	0.000	0%	0%
	Ethanol	00064-17-5	0.000	0.000	0%	0%	0.000	0.000	0%	0%
Total			241.803	7.624	100%	100%	470.738	14.834	100%	100%

482.047 SHED FID (mg)  
97.654 % GC of SHED 1

**Specific Reactivity Calculations** - The Carter Maximum Incremental Reactivity (MIR) scale for the various VOC molecules has been adopted by the CARB. It estimates that for each gram of the various VOC molecules, X grams of ozone would be produced under ideal conditions for ozone formation. The reference (approved by the CARB Staff for this purpose) to the values and the documentation is "THE SAPRC-99 CHEMICAL MECHANISM AND UPDATED VOC REACTIVITY SCALES" which can be found at;

<http://helium.ucr.edu/~carter/reactdat.htm>

The link to the actual data is found down two thirds of the page, under the heading VOC Reactivity Data (Excel format) as of February 5, 2003 (r02tab.xls). Appendix F (pgs 67-77) is a tabulation of MIR values taken from this Excel™ file. It contains CAS number, MIR value and species name for 543 different species.

We calculated the average specific reactivity of the permeate for each of the tests, on each of the rigs, and on each of the three fuels. Speciated data were collected and potential ozone reactivity was calculated for 92 tests, and are contained in the companion CD-ROM for the CRC E65 project as "Individual Reactivity File Calculations – 3 Fuels.xls"

VOC reactivity varies with atmospheric conditions, in particular the VOC/NOx ratio. The MIR scale is based on low VOC/NOx ratios. The reactivity measure reported in this study, average VOC specific reactivity, has units of potential grams of ozone per gram of VOC and is a function of the composition of the VOC permeate. Specific reactivity provides an estimate of the ozone-forming potential per unit mass of the VOC permeate under conditions favorable for ozone formation, but it is not meant to predict actual levels of ozone and should be interpreted on a relative basis. Further, there are uncertainties in these reactivity estimates, e.g., the MIR scale represents a limited range of atmospheric conditions, does not include carryover of emissions from one day to the next, and does not include three-dimensional spatial variation in emissions.

An abbreviated example of the specific reactivity calculations for Rig 1 – Day 1 on Fuel A is shown in Table 10. The left-most column is the elution number, followed by the Species Name, then the CAS Number<sup>8</sup>. The next column is the mass emissions for that compound. The listing has been reordered with the largest mass at the top of the list, then in decreasing order down to the lowest detected levels.

The fifth column is the MIR factor for that molecule. The mass emissions times the MIR gives the theoretical potential ozone that would be formed by that mass under ideal conditions, reported in the 6<sup>th</sup> or last column. We performed this calculation on all the identified molecules that had MIR factors. Not all the molecules measured had MIR factors. They were assumed to have the same reactivity as the average of the identified compounds with MIR factors. The mass of the compounds for which no MIR factors existed was determined to be insignificant.

---

<sup>8</sup> The CAS number is the Chemical Abstract Service registry number assigned to each specific molecule. CAS registry numbers are copyrighted by the American Chemical Society. Redistribution rights for CAS registry numbers are reserved by the American Chemical Society. "CAS registry" is a registered trademark of the American Chemical Society. The CAS REGISTRY mostly covers substances identified from the scientific literature from 1957 to the present with some classes (fluorine- and silicon-containing compounds) going back to the early 1900s. Each substance in REGISTRY is identified by a unique numeric identifier called a CAS Registry Number.

The specific reactivity for a speciated SHED diurnal sample was calculated by summing the mass of the individual species, and the predicted potential ozone using the MIR factor. The specific reactivity is the mass of ozone predicted divided by the mass of the hydrocarbons measured, in our example, 713.9 mg/233.9 mg, or 3.05 g potential O<sub>3</sub>/g VOC emissions.

Table 10  
Reactivity Calculation Example

	<u>Species Name</u>	<u>CAS #</u>	<u>VOC (mg)</u>	<u>MIR</u>	<u>O<sub>3</sub> (mg)</u>
81	Toluene	00108-88-3	47.503	3.97	188.59
33	MTBE	01634-04-4	33.333	0.78	26.00
18	2-Methylbutane (Isopentane)	00078-78-4	32.940	1.67	55.01
111	m-Xylene	00108-38-3	11.739	10.61	124.55
21	n-Pentane	00109-66-0	10.984	1.53	16.81
36	2-MePentane	00107-83-5	9.176	1.78	16.33
12	n-Butane	00106-97-8	6.863	1.32	9.06
53	Benzene	00071-43-2	6.424	0.81	5.20
40	n-Hexane	00110-54-3	5.789	1.43	8.28
49	Methylcyclopentane	00096-37-7	5.738	2.40	13.77
38	3-Methylpentane	00096-14-0	5.285	2.06	10.89
34	2,3-Dimethylbutane	00079-29-8	4.089	1.13	4.62
63	2,2,4-TriMePentane (IsoOctane)	00540-84-1	3.976	1.43	5.69
111	p-Xylene	00106-42-3	3.600	4.24	15.26
109	Ethylbenzene	00100-41-4	3.575	2.79	9.97



19	1-Pentene	00109-67-1	0.217	7.73	1.68
76	2,5-DiMeHexane	00592-13-2	0.208	1.66	0.35
75	2,4,4-Trimethyl-2-Pentene	00107-40-4	0.207	8.52	1.77
76	EtCyPentane	01640-89-7	0.200	2.25	0.45
101	2,4-Dimethylheptane	02213-23-2	0.192	1.46	0.28
16	c-2-Butene	00590-18-1	0.180	13.22	2.38
39	1-Hexene	00592-41-6	0.147	6.12	0.90
10	1-Butene	00106-98-9	0.130	10.22	1.33
115	Styrene	00100-42-5	0.061	1.94	0.12

VOC - mg 233.9

713.9 O<sub>3</sub> - mg

Specific Reactivity 3.05

The average specific reactivity (grams of potential ozone/gram of VOC) of the permeate by test fuel type was calculated by averaging the daily values for each of the available tests on each fuel. Table 11 shows the values used for Fuel A.

The first column in Table 11 is the fuel identifier, second is the Test ID (Rig number and the day of the test). The 3<sup>rd</sup> column, SHED VOC, is the value reported by the SHED test system for the mass (mg) in the SHED (including the EtOH if present). The 4<sup>th</sup> column is the total mass (mg) reported from the speciation results. The first row of data in the table shows 253 mg reported by the SHED, and 242 mg reported from the speciation – obviously good agreement for two separate analytical techniques. Other comparisons are not as good – “Rig 5 Day 1” differs by more than 500 mg (5%), but is still deemed within laboratory capability.

The 5<sup>th</sup> column is the mass of the speciated sample that had an assigned MIR factor. The chromatograph identifies VOC species for which there is no MIR factor in the documentation. The mass of the compounds for which no MIR factors existed was determined to be insignificant. It is assumed that this mass had the same average reactivity as the mass for which MIR factors exist.

Twenty tests were available for averaging for Fuel A permeate in Table 11 below. The average Fuel A reactivity of the permeate was 3.47.

Table 11  
Average Specific Reactivity of Permeate for Fuel A

Fuel	Test ID	SHED VOC mg	Speciated Total Mass mg	Speciated Mass with MIR Factors mg	Reactivity
A	Rig 1 Day 1	253	242	234	3.05
	Rig 1 Day 2	229	229	222	3.12
	Rig 2 Day 1	655	675	649	3.49
	Rig 2 Day 2	620	602	585	3.31
	Rig 3 Day 1	294	299	290	3.15
	Rig 3 Day 2	283	275	269	2.97
	Rig 4 Day 1	647	649	633	3.24
	Rig 4 Day 2	606	640	620	3.30
	Rig 5 Day 1	9688	9158	8568	3.68
	Rig 5 Day 2	8720	8432	8294	3.77
	Rig 6 Day 1	5358	5081	4872	3.63
	Rig 6 Day 2	3750	3276	3138	3.65
	Rig 7 Day 1	1310	1311	1267	3.66
	Rig 7 Day 2	1086	1100	1072	3.60
	Rig 8 Day 1	950	1242	1221	3.50
	Rig 8 Day 2	968	677	644	3.96
	Rig 9 Day 1	1964	1923	1846	3.68
	Rig 9 Day 2	1964	2016	1932	3.60
	Rig 10 Day 1	1956	1264	1214	3.51
	Rig 10 Day 2	1880	1891	1817	3.44
<b>Average Fuel A Permeate Specific Reactivity</b>					<b>3.47</b>

The values used to calculate the average specific reactivity of the permeate for Fuels B and C are presented in Tables 12 and 13.

Table 12  
Average Specific Reactivity of Permeate for Fuel B

Fuel	Test ID	SHED VOC mg	Speciated Total Mass mg	Speciated Mass with MIR Factors mg	Reactivity
	Rig 1 Day 1	1113	1112	1089	2.80
	Rig 1 Day 2	952	878	871	2.78
	Rig 2 Day 1	1527	1503	1463	3.28
	Rig 2 Day 2	1337	1308	1282	3.25
	Rig 3 Day 1	1508	1477	1443	3.12
	Rig 3 Day 2	1228	1185	1160	3.45
	Rig 4 Day 1	2306	2024	1977	2.73
	Rig 4 Day 2	2192	2230	2206	2.79
	Rig 5 Day 1	12517	12671	12156	3.84
	Rig 5 Day 2	10778	11217	10894	3.67
	Rig 6 Day 1	5080	5114	4955	3.75
	Rig 6 Day 2	4706	4955	4803	3.71
	Rig 7 Day 1	2418	2377	2313	3.67
	Rig 7 Day 2	2089	2055	1997	3.42
	Rig 8 Day 1	2939	2781	2739	2.89
	Rig 8 Day 2	2312	2178	2130	2.86
	Rig 9 Day 1	4796	4713	4482	3.33
	Rig 9 Day 2	4553	4451	4410	3.59
	Rig 10 Day 1	3846	3825	3704	3.37
	Rig 10 Day 2	3616	3462	3395	3.47
<b>Average Fuel B Permeate Specific Reactivity</b>					<b>3.27</b>

Table 13

**Average Specific Reactivity of Permeate for Fuel C**

Fuel	Test ID	SHED VOC mg	Speciated Total Mass mg	Speciated Mass with MIR Factors mg	Reactivity
C	Rig 1 Day 1	253	242	235	3.84
	Rig 1 Day 2	194	144	139	3.26
	Rig 2 Day 1	595	570	555	3.64
	Rig 2 Day 2	571	555	538	3.58
	Rig 3 Day 1	341	359	344	3.46
	Rig 3 Day 2	319	306	304	3.38
	Rig 4 Day 1	1225	1140	1109	3.40
	Rig 4 Day 2	1038	886	858	3.40
	Rig 5 Day 1	12418	12211	11771	3.84
	Rig 5 Day 2	10597	10677	10366	3.84
	Rig 6 Day 1	4269	3878	3737	3.90
	Rig 6 Day 2	3161	3239	3116	3.93
	Rig 7 Day 1	2157	2119	2073	3.38
	Rig 7 Day 2	1668	1638	1623	3.58
	Rig 8 Day 1	902	864	844	4.15
	Rig 8 Day 2	748	785	760	4.10
	Rig 9 Day 1	1839	1795	1743	3.93
	Rig 9 Day 2	1709	1652	1604	3.91
	Rig 10 Day 1	2382	2309	2236	3.63
	Rig 10 Day 2	2222	2084	2020	3.57
<b>Average Fuel C Permeate Specific Reactivity</b>					<b>3.66</b>

Analysis of the above data for all three fuels indicates that there is not a significant difference between the Day 1 and Day 2 results. Given that the Day 2 results are repeats of the Day 1 measurements (as opposed to replicates), the Day 1 and Day 2 results were averaged for further analysis (note that this does not affect the averages by fuel). The data were then fit to the model Reactivity = Fuel + Rig + constant. The average reactivities and the half difference limit based on the Tukey<sup>9</sup> multiple comparisons test with 95% confidence for the three test fuels are shown in Table 14:

Table 14  
Permeate Specific Reactivity

	Average Reactivity	95% C.L.
Fuel A	3.47	± 0.107
Fuel B	3.27	± 0.102
Fuel C	3.66	± 0.0753

A plot of the average permeate specific reactivity values and a representation of the Tukey test interval, using an expanded vertical scale, is shown in Figure 16.

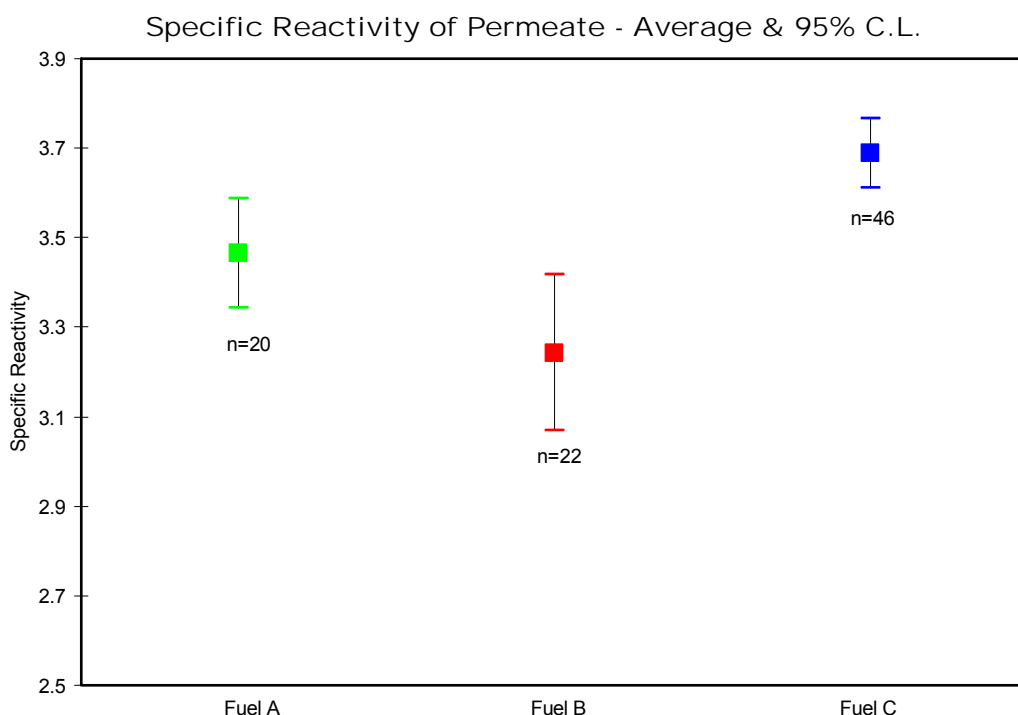

Figure 16

<sup>9</sup> J.W. Tukey, "Comparing Individual Means in the Analysis of Variance," *Biometrics*, **5**, 99, 1949  
The Tukey test is used here to account for the fact that we have more than two test fuels. For two fuels, the Tukey test is just the ordinary Student's t-test. The half least significant difference values are used to construct the confidence intervals, which enable us to determine whether the differences we measure between the three test fuels are statistically significant.

**The Increase in Non-Ethanol Hydrocarbons with Fuel B** – When the first results were accumulated on Fuel B (ethanol), it was observed that not only were the total permeation results higher than Fuel A (MTBE), but the non-ethanol hydrocarbons were also increased. This trend continued throughout the steady-state tests, with only one exception, and is shown in Figure 17. The exception was the Fuel C result on the 1995 MY (Rig 5). The middle bar of each group is the result from Fuel B. The bar is segmented into two components, the non-ethanol contribution in the lower red bar, and the ethanol component stacked on top in a pink color. The total height of the bar is the total permeation emissions as previously reported.

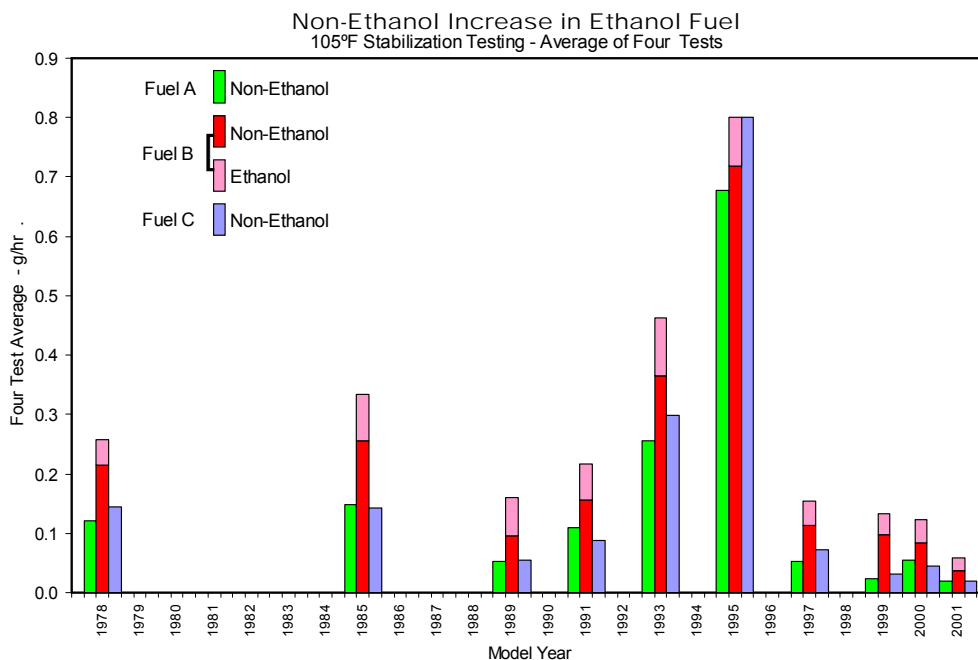

Figure 17

A similar increase was also observed in the results from the diurnal testing. Figure 18 is a similar plot, but showing diurnal test results instead of the steady-state measurements. Three exceptions to the general observation were noted:

1. The 1991 Honda Accord (Rig 7) – The Fuel C diurnal results were higher than the Fuel B non-ethanol hydrocarbons.
2. The 1993 Chevrolet Caprice (Rig 6) – The Fuel A diurnal results were higher than the Fuel B non-ethanol hydrocarbons.
3. The 1995 Ford Ranger (Rig 5) – The Fuel C diurnal results were higher than the Fuel B non-ethanol hydrocarbons, or the total of the non-ethanol and ethanol emissions.

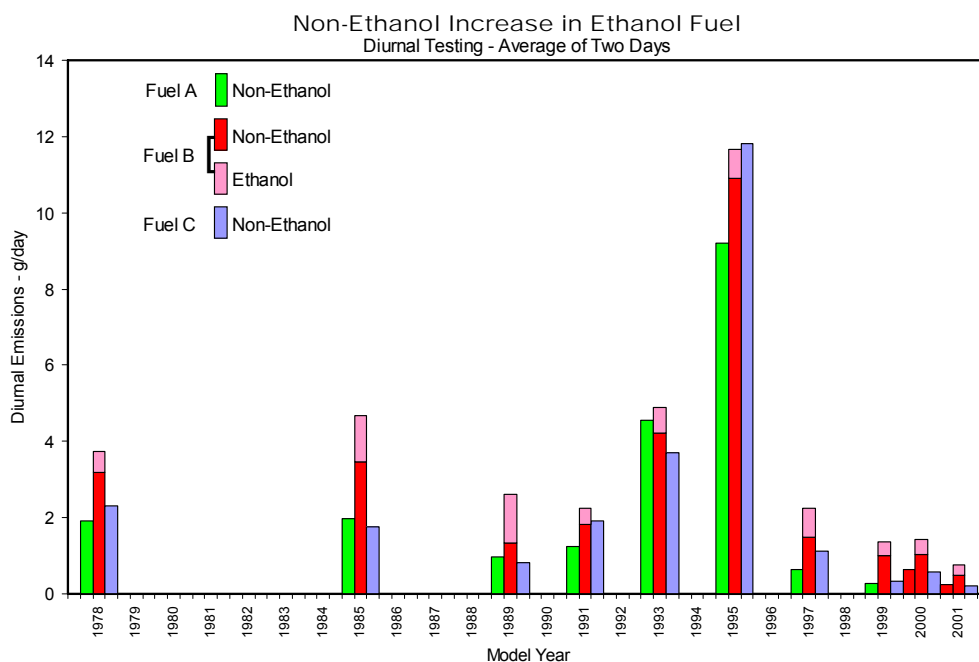

Figure 18

The general understanding is that permeation emissions increase when ethanol is added to gasoline. However there was little anticipation that the non-ethanol fraction would increase. At this time, there is no explanation for the cause of this observation. Two collections of references on the subject of gasoline permeation are included in the Companion CD-ROM: 1- "Literature Search Summary – Task 1 –Final.pdf" by Harold Haskew, and 2- "RFA's Literature Search – permeation study.pdf" by Robert Reynolds.

**Steady-State Test Results - 105°F and 85°F** - The original test plan requirement was to measure the steady-state permeation rate at 85°F, after the rig was deemed to be stabilized at 105°F. The interest in the lower temperature rate was driven by a position taken in a SAE paper, SAE 2001-01-0730, “Estimating Real Time Diurnal Permeation from Constant Temperature Measurements” by Marek Lockhart, et al. The authors suggested that real-time diurnal permeation test results can be estimated from constant temperature measurements. Our measurements add additional basis and support to the above position.

The permeation rates (in milligrams per hour) measured during the program are presented in Table 15.

Table 15  
Permeation Rates

Rig	Description	85° F Rate - mg/hr			105° F Rate - mg/hr		
		Fuel A	Fuel B	Fuel C	Fuel A	Fuel B	Fuel C
1	2001 Toyota Tacoma	9	32	10	20	58	19
2	2000 Honda Odyssey	21	53	19	55	123	44
3	1999 Toyota Corolla	10	57	11	24	133	31
4	1997 Chrysler Town & Country	23	66	40	52	155	72
5	1995 Ford Ranger	309	342	348	677	800	801
6	1993 Chevrolet Caprice Classic	95	137	94	255	463	298
7	1991 Honda Accord LX	40	100	39	110	217	88
8	1989 Ford Taurus GL	24	73	28	52	160	55
9	1985 Nissan Sentra	53	177	73	148	333	143
10	1978 Olds Cutlass Supreme	57	139	73	122	257	144
	Average	64	118	73	152	270	170

85° F Rate - If multiple tests were run, the average is shown.

105° F Rate - Rate shown is the average of the last four tests run.

The ratios of the 85°F test results to the 105°F results are shown in Table 16.

Table 16  
85°F to 105°F Ratio

Rig	Description	85°/105° Ratio		
		Fuel A	Fuel B	Fuel C
1	2001 Toyota Tacoma	0.46	0.54	0.50
2	2000 Honda Odyssey	0.39	0.43	0.43
3	1999 Toyota Corolla	0.43	0.43	0.37
4	1997 Chrysler Town & Country	0.45	0.43	0.55
5	1995 Ford Ranger	0.46	0.43	0.43
6	1993 Chevrolet Caprice Classic	0.37	0.30	0.32
7	1991 Honda Accord LX	0.36	0.46	0.44
8	1989 Ford Taurus GL	0.45	0.46	0.51
9	1985 Nissan Sentra	0.36	0.53	0.51
10	1978 Olds Cutlass Supreme	0.47	0.54	0.51
	Average	0.42	0.46	0.46

The relationship between the 85°F and the 105°F permeation measurements on Fuel A (as an example) is shown in Figure 19. The horizontal scale is the hourly permeation rate averaged for the last 4 weekly tests at 105°F. The vertical scale is the 85°F rate.

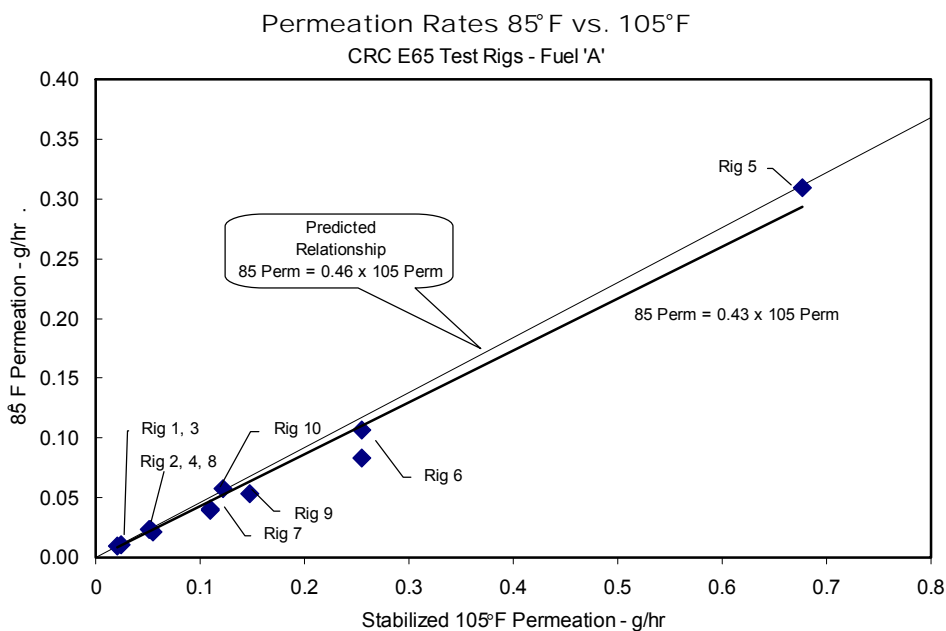

Figure 19

The balloon points to the upper of the two trend lines, which follows the relationship that permeation doubles for each 10°C increase; the rate of 85°F being 46% of the rate of 105°F. The lower line is the slope of the regression line fitted to the data. The data seem to follow the relationship well.

Since Rig 5 had emissions that were much higher than the rest of the fleet, we investigated whether it had a major influence on the relationship by recalculating the regression with the Rig 5 data omitted. Figure 20 shows the data and regression lines with and without Rig 5. The slope of the lines are similar for all three fuels with and without the Rig 5 data included.

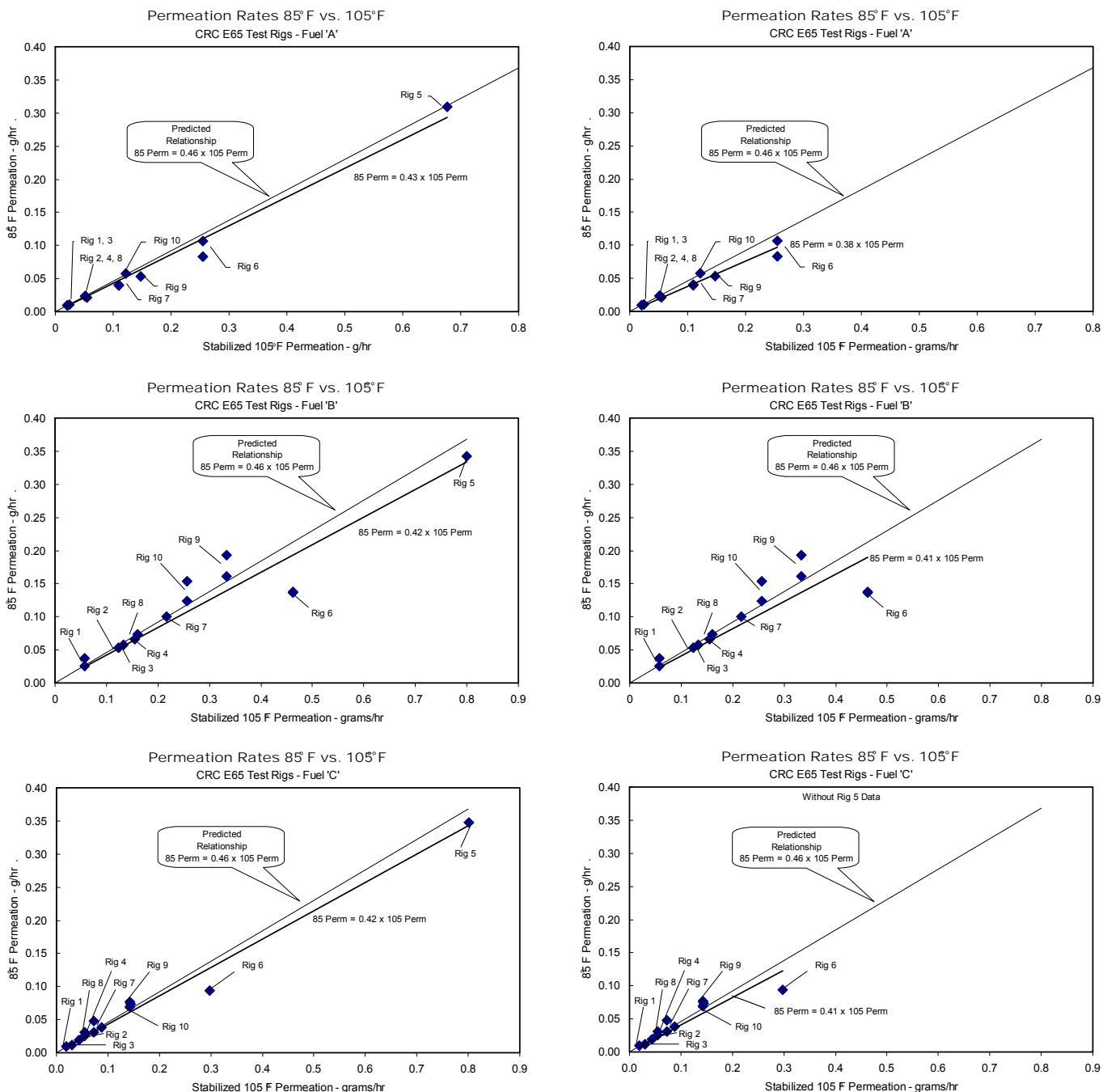

Figure 20

We also determined that the ratio between diurnal emissions and steady-state emissions was fairly consistent. This relationship was also mentioned in SAE paper, SAE 2001-01-0730, "Estimating Real Time Diurnal Permeation from Constant Temperature Measurements" by Marek Lockhart, et al. Figure 21 plots the diurnal and 105°F steady-state emissions. The ratio for the three fuels was 14.1.

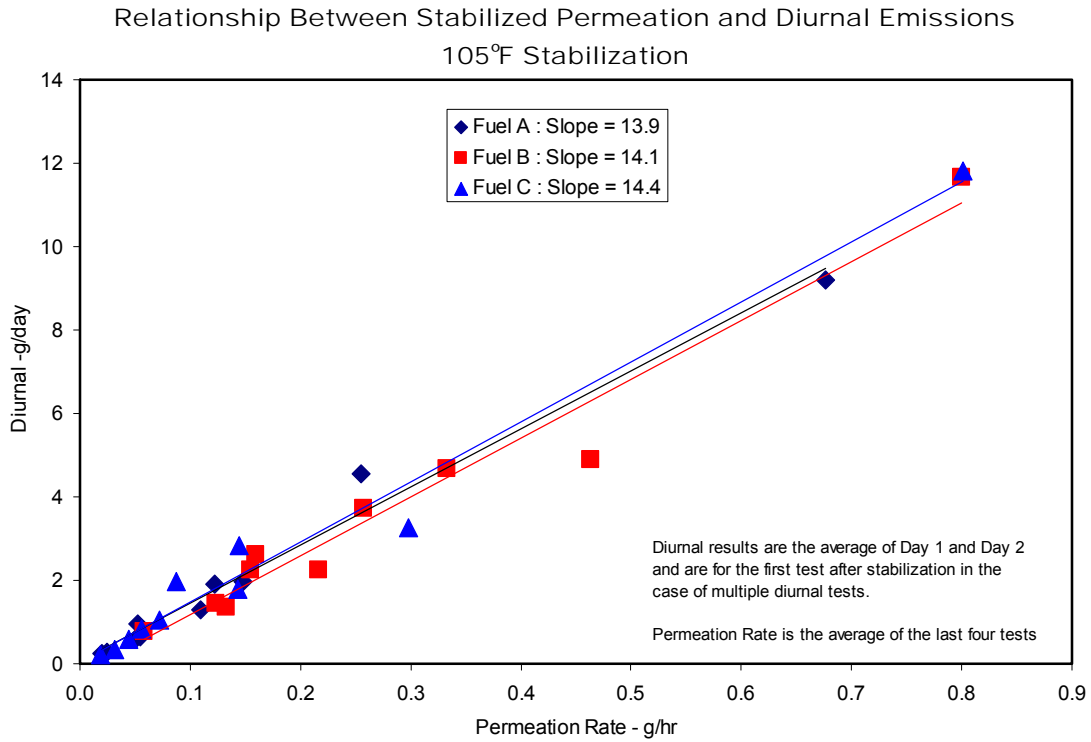

Figure 21

**Estimate of Experimental Variation** – After completion of the base program, replicate testing was performed on Fuel C to estimate the “repeatability” of the diurnal test results. This resulted in 9 pairs of “repeats” for Day 1 and Day 2. The repeatability data are presented in Table 17.

Table 17  
**Replicate Diurnal Test Results – Fuel C**

<b>Rig 01C</b>	<b>Day 1</b>	<b>Day 2</b>
Original Test Measurement (g/day)	0.278	0.174
Replicate	0.226	0.214
<b>Rig 02C</b>	<b>Day 1</b>	<b>Day 2</b>
Original Test Measurement (g/day)	0.593	0.583
Replicate	0.598	0.559
<b>Rig 03C</b>	<b>Day 1</b>	<b>Day 2</b>
Original Test Measurement (g/day)	0.340	0.310
Replicate	0.342	0.328
<b>Rig 04C</b>	<b>Day 1</b>	<b>Day 2</b>
Original Test Measurement (g/day)	1.109	1.004
Replicate	1.341	1.071
<b>Rig 05C</b>	<b>Day 1</b>	<b>Day 2</b>
Original Test Measurement (g/day)	13.571	11.268
Replicate	11.952	10.207
<b>Rig 06C</b>	<b>Day 1</b>	<b>Day 2</b>
Original Test Measurement (g/day)	3.568	2.979
Replicate	4.697	2.947
<b>Rig 07C</b>	<b>Day 1</b>	<b>Day 2</b>
Original Test Measurement (g/day)	2.230	1.712
Replicate	2.084	1.623
<b>Rig 09C</b>	<b>Day 1</b>	<b>Day 2</b>
Original Test Measurement (g/day)	1.874	1.697
Replicate	1.803	1.721
<b>Rig 10C</b>	<b>Day 1</b>	<b>Day 2</b>
Original Test Measurement (g/day)	2.809	2.832
Replicate	2.288	1.820

Rig 8 was not included in the replicate test program. The ~6 month time interval between when Rig 8 completed the Base Program and initiation of the Replicate Program was thought to be too long for the results to be acceptable.

The replicate data were used to determine the statistical significance of the effect of fuel changes on the diurnal emissions. First, the data by day were averaged, then the diurnal data for all three fuels were fit to a model designed to isolate the replicates in the determination of the experimental error (Diurnal emissions = Fuel + Rig + FuelxRig). The average permeation emissions of each of the three fuels, and the half difference limit based on the Tukey multiple comparisons test with 95% confidence, are shown in Table 18 below for the three test fuels:

Table 18  
Diurnal Emissions

	<u>Average Diurnal Emissions (g/day)</u>	<u>95% Limit</u>
Fuel A	2.16	± 0.243
Fuel B	3.56	± 0.243
Fuel C	2.45	± 0.185

A plot of the average diurnal emissions values and a representation of the Tukey test interval, using an expanded vertical scale, is offered in Figure 22 below:

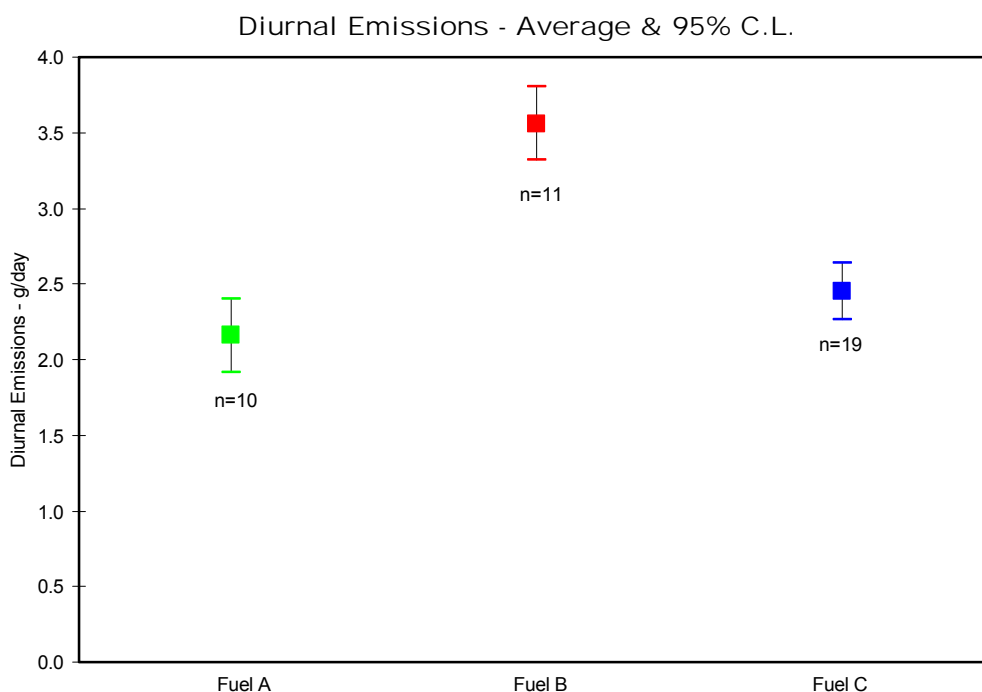

Figure 22

The analysis of the diurnal test results indicates that the differences between the ethanol fuel (Fuel B) and the other two fuels are statistically significant at the 95% confidence level. The difference between the emissions of the MTBE and non-oxygenated fuels are not significant at the 95% confidence level.

**Effect of Preconditioning Fill Level on Non-Metallic Tank Systems (100% vs. 20%)** - Four of the ten rigs featured non-metallic fuel tanks, and we wanted to determine the effect of the fill level on the permeation results. The basic procedure followed during the program was to soak the tanks with a 100% fill as we thought that this could give the fastest stabilization, and minimize the effects of the fuel “weathering” over time. We conducted additional stabilization on the four rigs with the non-metallic tanks at the end of the program, filling to 20% of capacity with Fuel C, re-stabilizing at 105°F, and then testing at 85°F, and conducting a two-day diurnal (diurnals are always conducted with a fresh fill of 40% of the test fuel). The results are presented in Table 19:

Table 19  
**Fill Level Effect - Steady-state Test Results**

	100% fill	20% fill	% Change
105°F test results	----- g/hour -----		
Rig 2	0.044	0.033	-25
Rig 4	0.072	0.056	-22
Rig 5	0.820	0.750	-9
Rig 6	0.298	0.277	-7
Average	0.308	0.279	
85°F test results			
Rig 2	0.019	0.013	-32
Rig 4	0.041	0.021	-49
Rig 5	0.349	0.350	0
Rig 6	0.094	0.095	+1
Average	0.126	0.120	
<u>Diurnal Test Results (40% fill)</u>			
	100% fill	20% fill	% Change
	Preconditioning		
Day 1	----- g/day -----		
Rig 2	0.596	0.435	-27
Rig 4	1.225	0.791	-35
Rig 5	11.952	12.857	+8
Rig 6	4.132	4.541	+10
Average	4.476	4.656	
Day 2			
Rig 2	0.571	0.422	-26
Rig 4	1.038	0.673	-35
Rig 5	10.207	10.982	+8
Rig 6	2.963	3.558	+20
Average	3.695	3.909	

The fill level test results are mixed. The newer fuel tank systems (rigs 2 and 4) showed lower permeation at lower fill levels on both the steady-state measurements, and on the 48 hour diurnal tests, despite the fact that the fill level during the actual diurnal test was unchanged at 40%. Rigs 5 and 6 showed slightly lower steady-state permeation rates (-7 and -9% of level) during the 105°F tests, but no difference at 85°F. The permeation rates increased during the diurnal evaluation.

## Appendix A

### Evaporative Emissions

The purpose of this project was to quantify the permeation emissions from a variety of vehicle fuel systems with three different fuel compositions used or contemplated for use in California. One of the challenges was to isolate the permeation component from the other sources of fuel, and non-fuel, emissions. This section documents the development of the evaporative emission test and the hardware used to control the emissions, and illustrates the solutions we used to focus only on the permeation emissions. We first discuss total evaporative emissions, the issue of “breathing losses”, permeation, then the steps we took to measure only permeation emissions.

Permeation is one component in the total evaporative emissions from a vehicle. The purpose of this section is to define and document permeation’s role in evaporative emissions

Evaporative emissions from motor vehicles can be defined as all the hydrocarbon (HC) emissions from a vehicle that do not come from the engine’s exhaust<sup>10</sup>. These non-tailpipe hydrocarbons come from a variety of sources, including non-fuel “background” sources such as tires, paint, vinyl components, and adhesives<sup>11</sup>. The major source of evaporative emissions has been from the vehicle’s fuel storage, delivery and handling systems.

The fuel tank, by design, is vented to the atmosphere through an activated carbon trap, and the normal daily tank emissions are highly controlled. Gasoline also escapes the vehicle’s fuel system by permeation through the plastic and rubber components; e.g., hoses, seals, and in some cases, such as with a non-metallic tank, the fuel tank itself. Advances in materials and design have reduced the permeation emissions component to very low levels.

An unintended source of HC emissions may occur from leaks in the system. Leaks may occur in the vapor and/or the liquid system as a result of deterioration and/or faulty service techniques.

Examples of deterioration are corrosion of metallic components (e.g., fuel lines, tanks), cracking of rubber hoses from heat and ozone exposure, hardening of seals, and mechanical failures. Deterioration of the elastomers has been greatly reduced for vehicles built in the middle 90s and later which are certified to the 10 year/100,000 mile requirements. The most restrictive emission control requirement is the California “Zero-Fuel-Evaporative Emissions”, which states that fuel emissions must be 0.0 g/day (less than 54 milligrams/day) for 15 years, or 150,000 miles.

Poor service techniques include the failure to properly reinstall and tighten connections, the use of inadequate repair materials, and the defeat (intended or unintended) of control devices such as valves and switches.

---

<sup>10</sup> William R. Pierson, et al., “Assessment of Nontailpipe Hydrocarbon Emissions from Motor Vehicles”, Journal of the Air & Waste Management Association, Volume 49 May 1999, ISSN 1047-3289

<sup>11</sup> Harold M. Haskew, “Real-Time Non-Fuel Background Emissions”, SAE 912373, International Fuels and Lubricants Meeting, Toronto, Canada, Oct 7-10, 1991.

## Appendix B

### A Vehicle's Fuel System

Evaporative emissions can escape from a wide variety of places on the vehicle. The purpose of this section is to define some terms and illustrate where leaks might occur.

Figure 23 is a simplified schematic of a typical vehicle fuel system. The fuel tank is usually located at the rear of the vehicle. A vapor volume space is provided above the liquid, even when the tank is "full", to allow for expansion, and help with the separation of the liquid from the vapor. The fill neck can be a separate component, connected to the tank in one or more places with rubber hose(s) and clamp(s). An external fill vent hose may be fitted from the top of the tank to the filler neck pocket.

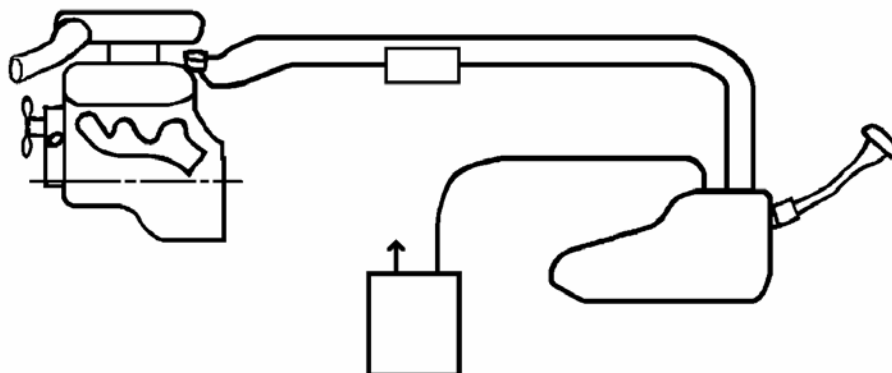

Figure 23. Vehicle Fuel System Schematic

Fuel injection vehicles typically have a fuel supply pump, mounted in the tank, drawing fuel from the bottom of the tank through a primary filter, or "sock". The supply pressure is maintained typically in the 10 psi range for throttle body injection systems, typical of the 1980's. Higher pressures, 40 to 60 psi, are used for port fuel injection systems.

The chassis supply line, typically a 8mm id tube, carries the pressurized fuel to the engine. The chassis supply line has typically been steel, and rigidly mounted to the underbody of the vehicle. Nylon has also been used for a number of years, and offers superior corrosion resistance. A serviceable fuel filter is usually fitted in the supply line. The chassis supply line is connected to the tank with a flexible hose for assembly, service, and isolation reasons. A similar flexible connection is made to the engine at the front of the vehicle. Many engine fuel systems use an engine mounted pressure regulator and return excess fuel back to the tank through a duplicate chassis return line. While the return line is not at the supply pressure, it is still pressurized, and an important component.

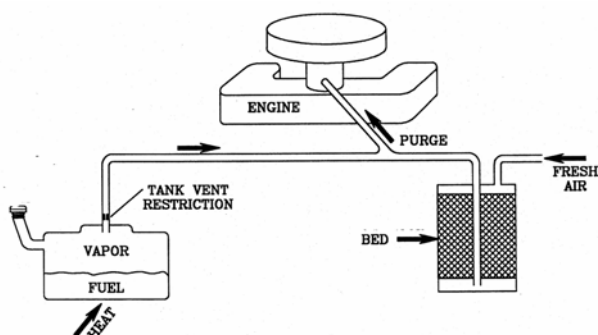

Figure 24. Evaporative Emission Control

Vapors from the tank are routed through a tank vent tube to a carbon canister for storage. The canister may be located in the engine compartment, which requires a long vapor tube, or close to the tank, which is required for the late 90's models with on-board control of refueling vapors. Vehicle

motion can produce “slosh” in the tank, and liquid can be trapped in the vent unless provisions have been made to separate it. Some applications use special liquid/vapor separators to ensure that only vapor is routed to the carbon canister. The canister is reactivated, or purged during engine operation by using engine vacuum to draw air through the carbon bed. The canister then has at least three connections, 1) the tank vapor vent, 2) the purge line, and 3) an air supply port.

The purge line to the engine may have a solenoid and/or a coolant temperature operated switch affixed to control the purge. This is sometimes mounted directly on the canister – other times on the engine. The vapor part of the system is therefore: the top of the tank, the fill pipe, the fill cap, the tank vent hose(s), the purge line, solenoids and switches, and the fresh air vent for the canister.

### **Appendix C**

#### **Isolating the Breathing Loss Emissions**

The intent was to measure the permeation performance of the vehicle fuel systems from vehicles in good repair. A brief review of fuel vapor emissions, including the “breathing losses” may be helpful. The tank, hoses, and controls are designed to contain the gasoline. Gasoline can escape the system by several mechanisms:

- Leaks
- Breathing losses (Vapor expelled during system temperature increases)
- Permeation

Leaks are an anomaly, and while they are present in the population of vehicles, are not thought to be sensitive to gasoline composition. By selecting vehicles in good repair, leaks should be eliminated from the measurements, even though this requirement would offer a possible challenge on the older vehicles.

Breathing losses are sometimes called “diurnal” losses and result from the fact that a vented fuel tank has to expel air and vapors during a temperature increase. A parked vehicle experiences temperature changes as the ambient temperature rises and then falls during the daily, or “diurnal” cycle. The plot in Figure 25 presents the equilibrium concentration of HC in the vented vapor space above liquid gasoline (such as would occur in an automotive fuel tank) for a range of temperatures.

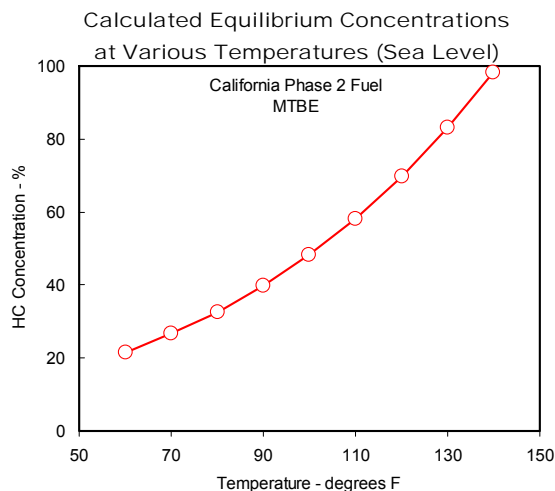

Figure 25

For example, at 70°F, the equilibrium concentration of hydrocarbons in the vapor space above the liquid fuel is 27%. If the temperature is increased to 80°F, the vapor pressure increases, and the equilibrium concentration in the vapor space increases to 32%. If the HC concentration above the fuel has to increase, and the vapor space is vented to the atmosphere and no

pressure increase can result, some vapor must be expelled. This is what we refer to as the “breathing loss.”

As described earlier, automotive evaporative emission control systems capture these expelled vapors in a canister filled with activated carbon (See SAE 902119, “Performance of Activated

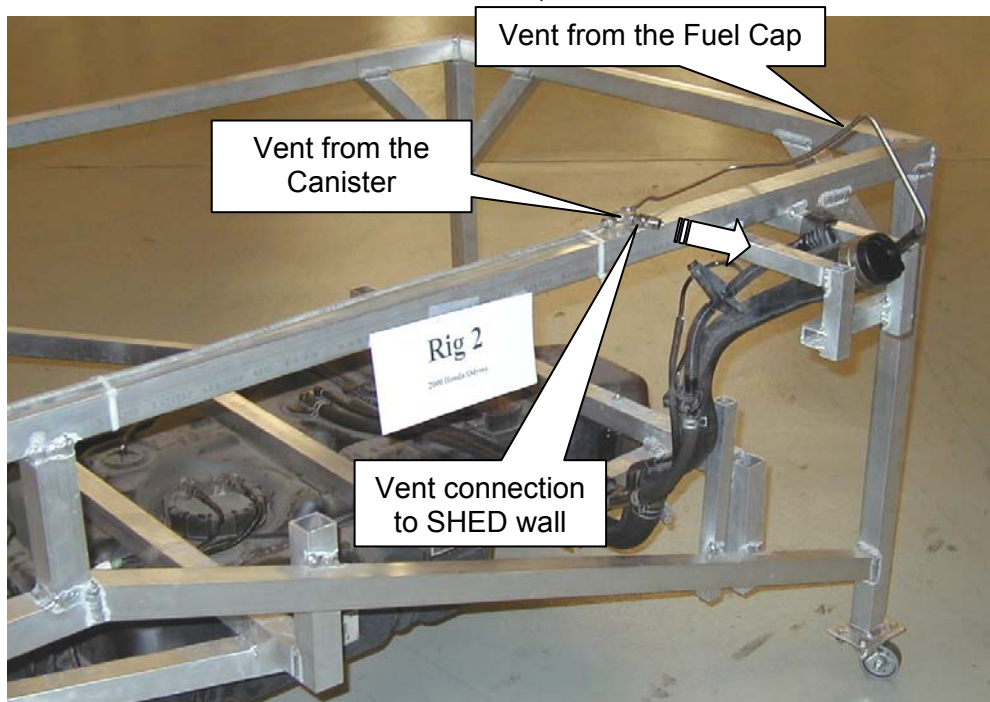

Figure 26. Test Rig 2

Carbon in Evaporative Loss Control Systems”, by H.R. Johnson and R.S. Williams). The HC molecules are temporarily stored on the carbon bed, and returned to the engine for combustion by drawing air through the bed while the engine is running.

For the purposes of this project, we were able to eliminate the contribution of the breathing losses by affixing a tube to the fuel tank system’s atmospheric vent and routing the vapors to the outside of the SHED through a bulk-head fitting in the enclosure. We also affixed a vent to the fuel cap, and combined this with the external vent, to prevent any pressurization in case a pressure control valve was fitted to the tank (an example is shown in Figure 26).



Figure 27. Open Bottom Canister

Figure 27 shows the fabricated cap that was fashioned and fitted to the open bottomed canister of Rig 10 (1978 Cutlass) to collect and route the canister vapors to the fittings that took any vapors outside the SHED.

## Appendix D

### Evaporative Emission Control Regulations

Evaporative emissions were first controlled nation-wide<sup>12</sup> in model year 1971. Carburetor and fuel tank vapors were routed to a small (about one liter) container of activated carbon for temporary storage and eventual use by the engine. Basic evaporative control hardware concepts (Carbon storage for tank vapors) have not changed much since then, but control effectiveness has increased greatly as materials, understanding and measurement techniques have improved.

The following summary provides an overview of the evolution of evaporative emission control regulations. These apply to Federal light-duty vehicles. California typically adopted regulations prior to the Federal rule. The model year that the regulation first affected is listed at the left margin. Many rules were phased in over three or more years.

1971	Carbon Trap Based Requirements (Diurnal + Hot Soak) <sup>13</sup> Diurnal test of 1 hour – Fuel heated from 60 to 84°F Hot Soak of 1 hour at Lab temperature after urban driving cycle
1978	Enclosure Based (SHED) Requirements – 6.0 grams <sup>14</sup> Diurnal test of 1 hour – Fuel heated from 60 to 84°F Hot Soak of 1 hour at Lab temperature after urban driving cycle
1981	Enclosure Based (SHED) Requirements – 2.0 grams <sup>15</sup> Diurnal test of 1 hour – Fuel heated from 60 to 84°F Hot Soak of 1 hour at Lab temperature after urban driving cycle
1996 to 1998	Enhanced Evaporative Emission Regulations - 2.0 grams (Multi-Day Diurnal & Running Loss) <sup>16</sup> Diurnal test of 24 hours – multiple days – Ambient temp heated from 65 to 105°F for California models with 7.0 psi RVP fuel. Federal test at 72 to 96°F with 9.0 psi RVP fuel. Certification Durability Requirements extended to 10 Years/ 100,000 miles.  Hot Soak of 1 hour at elevated temperature following extended high temperature driving  Running Losses controlled to 0.05 g/mile

---

<sup>12</sup> California typically has required controls one or more years prior to the Federal requirement.

<sup>13</sup> 33 FR 8304, June 4, 1968, “Standards for Exhaust Emissions, Fuel Evaporative Emissions, and Smoke Emissions, Applicable to 1970 [sic.] and Later Vehicles and Engines”

<sup>14</sup> 41 FR 25626, August 23, 1976, “Final Evaporative Emission Regulations for Light Duty Vehicles and Trucks”

<sup>15</sup> 43 FR 37970, August 24, 1978, “Evaporative Emission Regulations for Light-Duty Vehicles and Trucks”

<sup>16</sup> 58 FR 16002, March 24, 1993, “Evaporative Emission Regulations for Gasoline and Methanol-Fueled Light-Duty Vehicles, Light-Duty Trucks, and Heavy-Duty Vehicles”

1998 to 2000 On-Board Refueling Emission Controls<sup>17</sup> (Light duty Trucks from 2000 to 2004)  
Refueling control added to enhanced evap requirements

California required on-board diagnostic systems starting with model year 1988<sup>18</sup>. California later expanded the diagnostic requirements<sup>19</sup> to include (among many other things) leak checks on the evaporative control system, first affecting model year 1994. EPA adopted the California OBD II requirements<sup>20</sup> and required them on federal vehicles starting in model year 1998.

## **Appendix E**

### **Sealed Housing For Evaporative Determination (SHED)**

The enclosure technique for measuring evaporative emissions was first adopted for 1978 model year vehicle certification. The test subject is placed in a leak-proof box (Figure 6), and observed for a period of time. If fuel vapors are being emitted, the hydrocarbon concentration in the enclosure will increase. The mass of fuel vapors in the enclosure is calculated at the start of the observation period, and then again at some period later. The difference in the two estimates divided by the elapsed time is the time rate of mass emissions.

“Hot soak” emissions are measured over a 1 hour period (e.g., 40 CFR § 86.138-90). Mass is calculated from the net volume in the enclosure, the concentration of the fuel vapors, and the assumed average density of the mixture of vapors in the sample. The density is corrected for the local temperature and station pressure. The difference in fuel vapor mass over a period of time is the mass rate of emissions. The following quote is taken from the federal emissions test procedure at 40 CFR § 86.138-78 (The later procedures, -90 and -96 include methanol corrections, and are difficult to follow):

The basic form of the calculation is:       $\text{Mass} = \text{Volume} * \text{Concentration} * \text{Density}$

The Federal Register procedure is copied below.

---

<sup>17</sup> 59 FR 16262, April 6, 1994, “Refueling Emission Regulations for Light-Duty Vehicles and Light-Duty Trucks”

<sup>18</sup> Title 13 – California Code of Regulations section 1968

<sup>19</sup> Title 13 – California Code of Regulations section 1968.1

<sup>20</sup> Federal Register, 58 FR 9468, Feb. 19, 1993

**§ 86.143-78 Calculations; evaporative emissions.**

The calculation of the net hydrocarbon mass change in the enclosure is used to determine the diurnal and hot soak mass emissions. The mass is calculated from initial and final hydrocarbon concentrations in ppm carbon, initial and final enclosure ambient temperatures, initial and final barometric pressures, and net enclosure volume using the following equation:

$$M_{HC} = kV_n \times 10^{-4} \left[ \frac{C_{HCf} P_{Bf}}{T_f} - \frac{C_{HCi} P_{Bi}}{T_i} \right]$$

Where:

$M_{HC}$  = hydrocarbon mass, g.

$C_{HC}$  = hydrocarbon concentration as ppm carbon.

$V_n$  = net enclosure volume, ft<sup>3</sup> (m<sup>3</sup>) as determined by subtracting 50 ft<sup>3</sup> (1.42 m<sup>3</sup>) (volume of vehicle with trunk and windows open) from the enclosure volume. A manufacturer may use the measured volume of the vehicle (instead of the nominal 50 ft<sup>3</sup>) with advance approval by the Administrator: *Provided*, The measured volume is determined and used for all vehicles tested by that manufacturer.

$P_B$  = barometric pressure, in. Hg (kPa).

$T$  = enclosure ambient temperature, R (K).

$k = .208 (12 + H/C)$

for SI units,  $k = 1.2 (12 + H/C)$ .

Where:

H/C = Hydrogen-carbon ratio.

H/C = 2.33 for diurnal emissions.

H/C = 2.2 for hot soak emissions.

$i$  = indicates initial reading.

$f$  = indicates final reading.

The final reported results shall be computed by summing the individual evaporative emission results determined for the diurnal breathing-loss test, running-loss test, and the hot-soak test.

The volume of the enclosure is established with some degree of accuracy. The volume of the vehicle with the windows and trunk lid open is assumed to be 50 ft<sup>3</sup>, unless a more appropriate value is known. We used 5 ft<sup>3</sup> as an appropriate volume for the rigs. The SHEDs used were nominally 2000 ft<sup>3</sup> in volume, so even plus or minus 5 ft<sup>3</sup> for the net volume estimate is a small error.

ATL has 6 SHEDs (5 variable temperature, and 1 constant temperature) at the Mesa, AZ facility, as shown in Figure 28. These are basically aluminum boxes, 10' x 10' in width and height, and 20' long, with the necessary heating/cooling systems, HC sampling systems, and volume compensation devices for the VT-SHED models.

The sampling system draws a continuous sample from the enclosure during the test through a pump and pressure control device. A small portion is routed to the Flame Ionization Detector (FID) (See SAE 700468 and 770141 for FID basics) for establishing the hydrocarbon concentration in the sample. The balance of the sample is returned to the enclosure.

The one hour interval used for the automotive hot soak, and the 24 hour interval used to estimate the daily "diurnal" emissions, are the normally measured parameters. The concept of the enclosure method can be used over shorter intervals, and allow more information to be gained during a test.



Figure 28. ATL SHEDs

**Appendix F****Carter Reactivity Scale – Maximum Incremental Reactivity**

<u>CAS No.</u>	<u>MIR</u>	<u>Species</u>
50-00-0	8.96	Formaldehyde
56-23-5	0.00	Carbon Tetrachloride
56-81-5	3.26	Glycerol
57-55-6	2.74	Propylene Glycol
60-29-7	4.01	Diethyl Ether
64-17-5	1.69	Ethanol
64-18-6	0.08	Formic Acid
64-19-7	0.50	Acetic Acid
66-25-1	4.93	Hexanal
67-56-1	0.69	Methanol
67-63-0	0.71	Isopropyl Alcohol
67-64-1	0.43	Acetone
67-66-3	0.03	Chloroform
67-68-5	6.83	Dimethyl Sulfoxide
71-23-8	2.73	n-Propyl Alcohol
71-36-3	3.33	n-Butyl Alcohol
71-41-0	3.33	Pentyl Alcohol
71-43-2	0.81	Benzene
71-55-6	0.00	1,1,1-Trichloroethane
74-82-8	0.01	Methane
74-83-9	0.02	Methyl Bromide
74-84-0	0.31	Ethane
74-85-1	9.07	Ethene
74-86-2	1.24	Acetylene
74-87-3	0.03	Methyl Chloride
74-95-3	0.00	Methylene Bromide
74-96-4	0.11	Ethyl Bromide
74-98-6	0.56	Propane
74-99-7	6.44	Methyl Acetylene
75-00-3	0.25	Ethyl Chloride
75-01-4	2.92	Vinyl Chloride
75-04-7	7.79	Ethyl Amine
75-07-0	6.83	Acetaldehyde
75-09-2	0.07	Dichloromethane
75-18-3		Dimethyl Sulfide
75-19-4	0.10	Cyclopropane
75-21-8	0.04	Ethylene Oxide
75-28-5	1.34	Isobutane
75-34-3	0.10	1,1-Dichloroethane
75-35-4		1,1-Dichloroethene
75-50-3	7.06	Trimethyl Amine
75-56-9	0.32	Propylene Oxide
75-65-0	0.45	t-Butyl Alcohol
75-83-2	1.33	2,2-Dimethyl Butane
75-97-8	0.78	Methyl t-Butyl Ketone
77-68-9	0.86	3-Hydroxy-2,2,4-Trimethylpentyl-1-Isobutyrate

E65 Final Report - Fuel Permeation from Automotive Systems

77-76-9	0.52	2,2-Dimethoxy Propane
78-59-1	10.58	isophorone {3,5,5-trimethyl-2-cyclohexenone}
78-78-4	1.67	Iso-Pentane
78-79-5	10.68	Isoprene
78-83-1	2.23	Isobutyl Alcohol
78-84-2	5.86	2-Methylpropanal
78-85-3	6.18	Methacrolein
78-87-5		1,2-Dichloropropane
78-92-2	1.59	s-Butyl Alcohol
78-93-3	1.48	Methyl Ethyl Ketone
78-94-4	8.67	Methylvinyl ketone
78-98-8	16.21	Methyl Glyoxal
79-00-5	0.06	1,1,2-Trichloroethane
79-01-6	0.60	Trichloroethylene
79-09-4	0.79	Propionic Acid
79-10-7	11.57	Acrylic Acid
79-14-1	2.67	Glycolic Acid
79-20-9	0.07	Methyl Acetate
79-21-0		Peroxyacetic Acid
79-29-8	1.13	2,3-Dimethyl Butane
79-31-2	1.22	isobutyric acid
79-41-4	18.78	Methacrylic Acid
80-56-8	4.29	a-Pinene
80-62-6	15.84	Methyl Methacrylate
89-78-1	1.70	menthol
90-12-0	4.61	1-Methyl Naphthalene
91-08-7		2,6-Toluene Diisocyanate
91-20-3	3.26	Naphthalene
91-57-6	4.61	2-Methyl Naphthalene
94-65-5	1.71	2-propyl cyclohexanone
94-96-2	2.62	2-Ethyl-1,3-hexanediol
95-13-6	3.21	Indene
95-47-6	7.48	o-Xylene
95-48-7	2.34	o-Cresol
95-63-6	7.18	1,2,4-Trimethyl Benzene
96-14-0	2.06	3-Methylpentane
96-22-0	1.44	3-Pentanone
96-26-4	4.02	dihydroxyacetone
96-33-3	12.10	Methyl Acrylate
96-37-7	2.40	Methylcyclopentane
96-41-3	1.94	Cyclopentanol
96-47-9	4.59	Alpha-Methyltetrahydrofuran
96-48-0	1.15	gamma- butyrolactone
97-64-3	2.72	Ethyl Lactate
97-85-8	0.61	Isobutyl Isobutyrate
97-86-9	8.98	Isobutyl Methacrylate
97-88-1	9.08	Butyl Methacrylate
97-99-4	3.54	tetrahydro-2-furanmethanol
98-08-8	0.26	Benzotrifluoride
98-55-5	5.16	a-terpineol
98-56-6	0.11	p-Trifluoromethyl-Cl-Benzene

E65 Final Report - Fuel Permeation from Automotive Systems

98-82-8	2.32	Isopropyl Benzene (cumene)
98-83-9	1.71	a-Methyl Styrene
98-95-3	0.07	Nitrobenzene
100-41-4	2.79	Ethyl Benzene
100-42-5	1.94	Styrene
100-52-7	-0.61	Benzaldehyde
101-68-8	0.79	Methylene Diphenylene Diisocyanate
102-71-6	2.75	Triethanolamine
102-76-1	0.57	glyceryl triacetate
103-09-3	0.77	2-Ethyl-Hexyl Acetate
103-11-7	2.42	2-Ethyl-Hexyl Acrylate
103-65-1	2.20	n-Propyl Benzene
104-51-8	1.97	n-Butyl Benzene
104-76-7	2.18	2-Ethyl-1-Hexanol
105-05-5	3.36	p-Diethyl Benzene
105-37-3	0.79	Ethyl Propionate
105-46-4	1.43	s-Butyl Acetate
105-54-4	1.24	Ethyl Butyrate
105-57-7	3.68	acetal (1,1-diethoxyethane)
105-66-8	1.15	n-Propyl Butyrate
106-21-8	1.42	3,7-dimethyl-1-octanol
106-36-5	0.92	n-Propyl Propionate
106-42-3	4.24	p-Xylene
106-44-5	2.34	p-Cresol
106-46-7	0.20	p-Dichlorobenzene
106-63-8	5.05	isobutyl acrylate
106-65-0	0.23	Dimethyl Succinate
106-79-6	0.48	Dimethyl Sebacate
106-88-7	1.01	1,2-Epoxybutane
106-93-4	0.05	1,2-Dibromoethane
106-94-5	0.35	n-Propyl Bromide
106-97-8	1.32	n-Butane
106-98-9	10.22	1-Butene
106-99-0	13.47	1,3-Butadiene
107-00-6	6.18	Ethyl Acetylene
107-02-8	7.55	Acrolein
107-06-2	0.10	1,2-Dichloroethane
107-13-1		Acrylonitrile
107-21-1	3.36	Ethylene Glycol
107-22-2	14.22	Glyoxal
107-31-3	0.06	Methyl Formate
107-40-4	8.52	2,4,4-trimethyl-2-Pentene
107-41-5	1.03	2-Methyl-2,4-Pentanediol
107-46-0		Hexamethyldisiloxane
107-83-5	1.78	2-Methyl Pentane
107-87-9	3.06	2-Pentanone
107-92-6	1.78	butanoic acid
107-98-2	2.60	1-Methoxy-2-Propanol
108-01-0	4.75	Dimethylaminoethanol
108-05-4	3.26	Vinyl Acetate
108-08-7	1.63	2,4-Dimethyl Pentane

E65 Final Report - Fuel Permeation from Automotive Systems

108-10-1	4.28	4-Methyl-2-Pentanone
108-11-2	2.89	4-methyl-2-pentanol (methyl isobutyl carbinol)
108-20-3	3.56	diisopropyl ether
108-21-4	1.12	Isopropyl Acetate
108-32-7	0.25	Propylene Carbonate
108-38-3	10.61	m-Xylene
108-39-4	2.34	m-Cresol
108-65-6	1.69	1-Methoxy-2-Propyl Acetate
108-67-8	11.22	1,3,5-Trimethyl Benzene
108-82-7	2.37	2,6-dimethyl-4-heptanol
108-83-8	2.90	Di-isobutyl ketone (2,6-dimethyl-4-heptanone)
108-84-9	1.46	methyl amyl acetate (4-methyl-2-pentanol acetate)
108-87-2	1.97	Methylcyclohexane
108-88-3	3.97	Toluene
108-90-7	0.36	Monochlorobenzene
108-93-0	2.23	Cyclohexanol
108-94-1	1.59	Cyclohexanone
108-95-2	1.82	Phenol
109-21-7	1.10	n-Butyl Butyrate
109-60-4	0.86	Propyl Acetate
109-65-9	0.60	n-Butyl Bromide
109-66-0	1.53	n-Pentane
109-67-1	7.73	1-Pentene
109-69-3		1-Chlorobutane
109-86-4	2.97	2-Methoxyethanol
109-87-5	1.04	Dimethoxy methane
109-94-4	0.52	Ethyl Formate
109-99-9	4.91	Tetrahydrofuran
110-00-9	16.54	Furan
110-12-3	2.10	5-Methyl-2-Hexanone
110-19-0	0.67	Isobutyl Acetate
110-43-0	2.77	2-Heptanone
110-49-6	1.18	2-Methoxyethyl Acetate
110-54-3	1.43	n-Hexane
110-62-3	5.71	Pentanal (Valeraldehyde)
110-63-4	3.22	1,4-butanediol
110-74-7	0.92	n-Propyl Formate
110-80-5	3.76	2-Ethoxyethanol
110-82-7	1.44	Cyclohexane
110-83-8	5.40	Cyclohexene
110-98-5	2.47	Dipropylene Glycol Isomer (1-[2-hydroxypropyl]-2-propanol)
111-13-7	1.64	2-Octanone
111-15-9	1.88	2-Ethoxyethyl Acetate
111-27-3	2.72	1-Hexanol
111-30-8	4.79	Glutaraldehyde
111-35-3	4.22	3-Ethoxy-1-Propanol
111-42-2	4.05	Diethanol Amine
111-43-3	3.23	Di n-Propyl Ether
111-46-6	3.53	Diethylene Glycol
111-55-7	0.73	Ethylene Glycol Diacetate
111-65-9	1.09	n-Octane

E65 Final Report - Fuel Permeation from Automotive Systems

111-66-0	3.42	1-Octene
111-70-6	2.19	1-Heptanol
111-71-7	4.19	Heptanal
111-76-2	2.88	2-Butoxyethanol
111-77-3	2.88	2-(2-Methoxyethoxy) Ethanol
111-82-0	0.53	methyl dodecanoate {methyl laurate}
111-84-2	0.93	n-Nonane
111-87-5	1.99	1-Octanol
111-90-0	3.34	2-(2-Ethoxyethoxy) Ethanol
112-06-1	0.73	n-Heptyl Acetate
112-07-2	1.65	2-Butoxyethyl Acetate
112-14-1	0.64	n-Octyl Acetate
112-15-2	1.49	2-(2-Ethoxyethoxy) ethyl acetate
112-25-4	2.43	2-Hexyloxyethanol
112-27-6	3.41	triethylene glycol
112-30-1	1.22	1-decanol
112-34-5	2.87	2-(2-Butoxyethoxy)-Ethanol
112-35-6	2.59	2-[2-(2-Methoxyethoxy) ethoxy] ethanol
112-40-3	0.64	n-Dodecane
112-41-4	1.74	1-Dodecene
112-50-5	2.64	2-[2-(2-Ethoxyethoxy) ethoxy] Ethanol
112-59-4	2.00	2-(2-Hexyloxyethoxy) Ethanol
112-60-7	2.84	tetraethylene glycol
112-95-8	0.40	n-C20
115-07-1	11.57	Propene
115-10-6	0.93	Dimethyl Ether
115-11-7	6.31	Isobutene
115-18-4	5.08	2-Methyl-3-Butene-2-ol
115-77-5	2.42	pentaerythritol
116-09-6	3.08	Hydroxy Acetone
119-64-2	2.83	Tetralin
120-92-3	1.42	Cyclopentanone
122-99-6	3.61	2-Phenoxyethanol; Ethylene glycol phenyl ether
123-04-6		3-(Chloromethyl)-Heptane
123-17-1	1.55	Trimethylnonanolthreoerythro; 2,6,8-Trimethyl-4-nonanol
123-18-2	1.86	2,6,8-trimethyl-4-nonanone; Isobutyl heptyl ketone
123-38-6	7.88	Propionaldehyde
123-42-2	0.68	Diacetone Alcohol
123-51-3	2.73	isoamyl alcohol (3-methyl-1-butanol)
123-54-6	1.02	2,4-pentanedione
123-72-8	6.68	Butanal
123-86-4	0.88	n-Butyl Acetate
123-91-1	2.71	1,4-dioxane
123-92-2	1.18	isoamyl acetate (3-methylbutyl acetate)
124-04-9	3.37	adipic acid
124-10-7	0.47	methyl myristate {methyl tetradecanoate}
124-11-8	2.73	1-Nonene
124-13-0	3.62	Octanal
124-16-3	2.08	1-(butoxyethoxy)-2-propanol
124-17-4	1.36	2-(2-Butoxyethoxy) ethyl acetate
124-18-5	0.81	n-Decane

E65 Final Report - Fuel Permeation from Automotive Systems

124-40-3	9.37	Dimethyl Amine
124-68-5	4.75	2-Amino-2-Methyl-1-Propanol
127-18-4	0.04	Perchloroethylene
127-91-3	3.28	b-Pinene
135-01-3	5.92	o-Diethyl Benzene
135-98-8	1.97	s-Butyl Benzene
137-32-6	2.60	2-methyl-1-butanol
140-88-5	8.73	Ethyl Acrylate
141-32-2	5.52	n-butyl acrylate
141-43-5	5.96	Ethanolamine
141-78-6	0.64	Ethyl Acetate
141-79-7	17.37	mesityl oxide (2-methyl-2-penten-4-one)
141-93-5	8.39	m-Diethyl Benzene
142-29-0	7.32	Cyclopentene
142-68-7	3.78	Tetrahydropyran
142-82-5	1.26	n-Heptane
142-92-7	0.87	n-Hexyl Acetate
142-96-1	3.14	Di-n-butyl Ether
143-13-5	0.58	n-Nonyl Acetate
143-22-6	2.21	2-[2-(2-Butoxyethoxy) ethoxy] Ethanol
144-19-4	1.76	2,2,4-Trimethyl-1,3-Pentanediol
149-57-5	3.49	2-Ethyl Hexanoic Acid
156-60-5	0.81	Trans-1,2-Dichloroethene
287-23-0	1.04	Cyclobutane
287-92-3	2.67	Cyclopentane
291-64-5	2.23	Cycloheptane
292-64-8	1.70	Cyclooctane
431-03-8	20.73	Biacetyl
463-82-1	0.69	Neopentane
464-06-2	1.32	2,2,3-Trimethyl Butane
496-11-7	3.16	Indan
503-17-3	16.32	2-Butyne
503-30-0	5.19	Trimethylene Oxide
503-74-2	4.26	3-Methylbutanoic acid
513-35-9	14.44	2-Methyl-2-Butene
526-73-8	11.25	1,2,3-Trimethyl Benzene
527-53-7	8.25	1,2,3,5 Tetramethyl Benzene
540-84-1	1.43	2,2,4-Trimethyl Pentane
540-88-5	0.20	t-Butyl Acetate
541-02-6		D5 Cyclosiloxane
542-92-7	7.55	Cyclopentadiene
544-76-3	0.50	n-C16
547-63-7	0.69	Methyl Isobutyrate
547-64-8	2.76	Methyl Lactate
554-12-1	0.71	Methyl Propionate
556-67-2		D4 Cyclosiloxane
558-37-2	6.02	3,3-Dimethyl-1-Butene
562-49-2	1.32	3,3-Dimethyl Pentane
563-45-1	6.95	3-Methyl-1-Butene
563-46-2	6.47	2-Methyl-1-Butene
563-78-0	4.75	2,3-Dimethyl-1-Butene

E65 Final Report - Fuel Permeation from Automotive Systems

563-79-1	13.32	2,3-Dimethyl-2-Butene
563-80-4	1.64	Methyl Isopropyl Ketone
565-59-3	1.53	2,3-Dimethyl Pentane
565-75-3	1.22	2,3,4-Trimethyl Pentane
565-80-0	1.61	Di-Isopropyl Ketone
581-40-8	5.54	2,3-Dimethyl Naphthalene
584-02-1	1.73	3-Pentanol
584-03-2	2.20	1,2-Butandiol
584-84-9	-0.13	2,4-Toluene Diisocyanate
584-94-1	1.32	2,3-Dimethyl Hexane
589-34-4	1.84	3-Methyl Hexane
589-43-5	1.79	2,4-Dimethyl Hexane
589-53-7	1.46	4-Methyl Heptane
589-62-8	3.04	4-Octanol
589-81-1	1.33	3-Methyl Heptane
590-01-2	0.87	Butyl Propionate
590-18-1	13.22	cis-2-Butene
590-35-2	1.21	2,2-Dimethyl Pentane
590-73-8	1.12	2,2-Dimethyl Hexane
590-86-3	5.47	3-Methylbutanal (Isovaleraldehyde)
591-21-9	1.69	1,3-Dimethyl Cyclohexane
591-47-9	4.44	4-Methyl Cyclohexene
591-49-1	7.70	1-Methyl Cyclohexene
591-76-4	1.36	2-Methyl Hexane
591-78-6	3.53	Methyl n-Butyl Ketone
592-13-2	1.66	2,5-Dimethyl Hexane
592-27-8	1.18	2-Methyl Heptane
592-41-6	6.12	1-Hexene
592-43-8	8.35	2-Hexenes
592-76-7	4.20	1-Heptene
592-84-7	0.94	n-Butyl Formate
593-45-3	0.44	n-C18
594-56-9	4.59	2,3,3-trimethyl-1-Butene
594-82-1	0.44	2,2,3,3-Tetramethyl Butane
598-98-1	0.39	Methyl Pivalate
611-14-3	6.61	o-Ethyl Toluene
616-38-6	0.06	Dimethyl Carbonate
620-14-4	9.37	m-Ethyl Toluene
622-58-2	0.94	Para Toluene Isocyanate
622-96-8	3.75	p-Ethyl Toluene
623-42-7	1.16	Methyl Butyrate
623-84-7	0.94	1,2-Propylene glycol diacetate
624-41-9	1.17	2-methyl-1-butyl acetate
624-54-4	0.79	n-pentyl propionate
624-64-6	13.90	trans-2-Butene
624-91-9		Methyl Nitrite
625-27-4	11.87	2-Methyl-2-Pentene
625-54-7	3.86	Ethyl Isopropyl Ether
625-55-8	0.42	Isopropyl Formate
626-93-7	2.45	2-Hexanol
627-20-3	10.23	cis-2-Pentene

E65 Final Report - Fuel Permeation from Automotive Systems

627-93-0	1.94	Dimethyl Adipate
628-28-4	3.63	Methyl n-Butyl Ether
628-55-7	1.29	Di-Isobutyl Ether
628-63-7	0.94	Amyl Acetate
628-81-9	3.84	Ethyl n-Butyl Ether
629-14-1	2.84	ethylene glycol diethyl ether; 1,2-diethoxyethane
629-50-5	0.60	n-Tridecane
629-59-4	0.56	n-Tetradecane
629-62-9	0.53	n-Pentadecane
629-78-7	0.47	n-C17
629-92-5	0.42	n-C19
629-94-7	0.38	n-C21
629-97-0	0.36	n-C22
630-08-0	0.06	Carbon Monoxide
630-19-3	5.40	2,2-Dimethylpropanal (pivaldehyde)
637-92-3	2.11	Ethyl t-Butyl Ether
646-04-8	10.23	trans-2-Pentene
646-06-0	5.47	1,3-dioxolane
690-08-4	6.92	Trans 4,4-dimethyl-2-Pentene
690-93-7	5.90	Trans 2,2-Dimethyl 3-Hexene
691-37-2	6.21	4-Methyl-1-Pentene
692-70-6	5.37	Trans 2,5-Dimethyl 3-Hexene
693-54-9	1.04	2-Decanone
693-65-2	2.60	Di-n-Pentyl Ether
693-89-0	13.44	1-Methyl cyclopentene
760-20-3	6.17	3-Methyl-1-Pentene
760-21-4	5.01	2-Ethyl-1-Butene
763-29-1	5.15	2-Methyl-1-Pentene
763-69-9	3.59	Ethyl 3-Ethoxy Propionate
764-97-6	4.18	Trans-5-Undecene
770-35-4	1.73	1-phenoxy-2-propanol
821-55-6	1.28	2-Nonanone
821-95-4	1.93	1-Undecene
871-83-0	0.83	2-Methyl Nonane
872-05-9	2.25	1-Decene
872-50-4	2.55	N-Methyl-2-Pyrrolidone
919-94-8	2.03	4,4-Dimethyl-3-oxahexane
925-54-2	3.97	2-methyl-hexanal
926-82-9	1.61	3,5-Dimethyl Heptane
994-05-8	2.14	Methyl t-Amyl Ether
1002-43-3	0.68	3-Methyl Undecane
1004-29-1	2.49	2-Butyl Tetrahydrofuran
1067-20-5	1.34	3,3-Diethyl Pentane
1069-53-0	1.31	2,3,5-Trimethyl Hexane
1119-40-0	0.50	Dimethyl Glutarate
1120-21-4	0.72	n-Undecane
1120-36-1	1.38	1-Tetradecene
1191-95-3	0.68	Cyclobutanone
1319-77-3	2.34	C7 Alkyl Phenols
1320-67-8	4.01	3-methoxy-1-propanol
1321-60-4	2.17	trimethylcyclohexanol

E65 Final Report - Fuel Permeation from Automotive Systems

1321-94-4	4.61	Methyl Naphthalenes
1330-20-7	7.48	C8 Disubstituted Benzenes
1559-34-8	1.86	3,6,9,12-Tetraoxahexadecan-1-ol
1559-35-9	1.68	2-(2-Ethylhexyloxy) Ethanol
1569-01-3	2.84	1-Propoxy-2-Propanol (Propylene glycol n-propyl ether)
1569-02-4	3.23	1-Ethoxy-2-Propanol
1589-47-5	3.00	2-Methoxy-1-Propanol
1632-70-8	0.69	5-Methyl Undecane
1634-04-4	0.78	Methyl t-Butyl Ether
1640-89-7	2.25	Ethyl Cyclopentane
1674-10-8	6.66	1,2-Dimethyl Cyclohexene
1678-91-7	1.72	Ethylcyclohexane
1678-92-8	1.45	Propyl Cyclohexane
1678-93-9	1.05	Butyl Cyclohexane
1678-99-5	1.31	1,3-Diethyl-Cyclohexane
1679-00-1	1.46	1,4-Diethyl-Cyclohexane
1795-15-9	0.58	Octyl Cyclohexane
1795-16-0	0.48	Decyl Cyclohexane
1871-57-4	3.13	2-(Cl-methyl)-3-Cl-Propene
2040-96-2	1.89	Propyl Cyclopentane
2050-01-3	0.88	Isoamyl Isobutyrate
2051-30-1	1.24	2,6-Dimethyl Octane
2213-23-2	1.46	2,4-Dimethyl Heptane
2216-32-2	1.42	4-Ethyl Heptane
2216-34-4	1.05	4-Methyl Octane
2437-56-1	1.52	1-Tridecene
2453-00-1	2.13	1,3-Dimethyl Cyclopentane
2517-43-3	0.97	3-Methoxy-1-Butanol
2550-21-2	2.81	3-Methyl-2-Hexanone
2807-30-9	3.50	2-Propoxyethanol
2847-72-5	0.78	4-Methyl Decane
2882-96-4	0.48	3-Methyl Pentadecane
2883-02-5	0.52	Nonyl Cyclohexane
2918-23-2	5.56	hydroxypropyl acrylate
3073-66-3	1.34	1,1,3-Trimethyl Cyclohexane
3178-29-8	1.22	4-Propyl Heptane
3221-61-2	0.94	2-Methyl Octane
3387-41-5	3.66	Sabinene
3522-94-9	1.31	2,2,5-Trimethyl Hexane
3638-35-5	1.51	Isopropyl Cyclopropane
3683-22-5	7.82	Trans 4-Methyl-2-Hexene
3728-56-1	1.59	1-Ethyl-4-Methyl Cyclohexane
4032-94-4	1.07	2,4-Dimethyl Octane
4050-45-7	8.35	Trans-2-Hexene
4128-31-8	2.13	2-Octanol
4170-30-3	9.96	Crotonaldehyde
4292-75-5	0.72	Hexyl Cyclohexane
4292-92-6	0.89	Pentyl Cyclohexane
5131-66-8	2.73	n-Butoxy-2-Propanol (Propylene Glycol n-Butyl Ether)
5617-41-4	0.63	Heptyl Cyclohexane
5878-19-3	2.13	Methoxy Acetone

E65 Final Report - Fuel Permeation from Automotive Systems

5911-04-6	0.86	3-Methyl Nonane
5989-27-5	3.99	d-Limonene
6032-29-7	1.73	2-Pentanol
6165-40-8	0.49	7-Methyl Pentadecane
6224-52-8	0.66	3,8-Diethyl Decane
6418-41-3	0.55	3-Methyl Tridecane
6482-34-4	1.04	Diisopropyl Carbonate
6881-94-3	2.97	2-(2-Propoxyethoxy) ethanol
6915-15-7	7.51	malic acid
6920-22-5	2.73	1,2-Dihydroxy Hexane
6938-94-9	1.42	diisopropyl adipate
7145-20-2	10.40	2,3-Dimethyl-2-Hexene
7206-16-8	3.70	Trans-5-Dodecene
7212-53-5	1.95	5-methyl-1-heptanol
7379-12-6	1.77	2-Methyl-3-Hexanone
7433-78-5	4.83	Cis-5-Decene
7642-09-3	8.13	Cis-3-Hexene
7642-10-6	6.88	Cis-3-Heptene
7642-15-1	5.86	Cis-4-Octene
7688-21-3	8.35	Cis-2-Hexene
10143-23-4	2.51	dimethylpentanol (2,3-dimethyl-1-pentanol)
10405-85-3	5.24	Trans-4-Nonene
10574-36-4	12.84	Cis-3-Methyl-2-Pentene
13151-34-3	0.74	3-Methyl Decane
13254-34-7	1.07	dimethylheptanol (2,6-dimethyl-2-heptanol)
13269-52-8	8.07	Trans-3-Hexene
13286-72-1	0.59	3,9-Diethyl Undecane
13287-21-3	0.59	6-Methyl Tridecane
13360-61-7	1.27	1-Pentadecene
13466-78-9	3.21	3-Carene
13588-28-8	2.70	Dipropylene Glycol Methyl Ether isomer (2-[2-methoxypropoxy]-1-propanol)
14638-54-1	0.94	2,4,6,8-Tetramethyl Nonane
14686-13-6	7.26	Trans-2-Heptene
14686-14-7	6.88	Trans-3-Heptene
14850-23-8	5.83	Trans-4-Octene
14919-01-8	6.06	Trans-3-Octene
15764-24-6	2.75	dipropylene glycol ethyl ether
16580-24-8	1.23	1-Methyl-3-Isopropyl Cyclohexane
17301-28-9	0.79	3,6-Dimethyl Undecane
17301-94-9	0.96	4-Methyl Nonane
17302-28-2	0.92	2,6-Dimethyl Nonane
17312-53-7	0.85	3,6-Dimethyl Decane
17312-57-1	0.61	3-Methyl Dodecane
17453-93-9	0.62	5-Methyl Dodecane
18435-22-8	0.51	3-Methyl Tetradecane
18491-15-1	0.91	1-Hydroxy-2,2,4-Trimethylpentyl-3-Isobutyrate
19398-77-7	1.18	3,4-Diethyl Hexane
19398-89-1	4.44	Trans-4-Decene
20296-29-1	2.53	3-Octanol
20710-38-7	13.54	Trans 3-Methyl-2-Hexene

E65 Final Report - Fuel Permeation from Automotive Systems

23051-84-5	3.34	Trans-5-Tridecene
23305-64-8	2.43	2-[2-(2-Propoxyethoxy) ethoxy] Ethanol
23783-42-8	2.13	2,5,8,11-Tetraoxatridecan-13-ol
25265-77-4	0.88	Texanol isomers
25339-17-7	1.21	8-Methyl-1-Nonanol (Isodecyl Alcohol)
25498-49-1	1.88	Tripropylene Glycol Monomethyl Ether
25551-13-7	9.90	C9 Trisubstituted Benzenes
26471-62-5		Toluene Diisocyanate (mixed isomers)
26730-16-5	0.55	6-Methyl Tetradecane
29911-28-2	1.96	glycol ether dpnb {1-(2-butoxy-1-methylethoxy)-2-propanol}
30136-13-1	3.84	n-propoxypropanol
39762-40-8	0.53	1-Methyl-4-Nonyl Cyclohexane
40364-84-9	6.56	Hydroxy Methacrolein
40649-36-3	2.08	4-propyl cyclohexanone
41446-66-6	3.03	Trans-5-Tetradecene
51729-83-0	0.69	Methyl Isopropyl Carbonate
56539-66-3	1.73	3 methoxy -3 methyl-Butanol
57018-52-7	1.70	1-tert-Butoxy-2-Propanol
59643-70-8	3.90	3,4-Diethyl-2-Hexene
61168-10-3	3.39	1-nonene-4-one
61868-54-0	1.26	2,3,4,6-Tetramethyl Heptane
61869-02-1	1.18	3,5-Diethyl Heptane
62183-94-2	1.07	2,6-Diethyl Octane
62199-32-0	1.06	2,3,5,7-Tetramethyl Octane
62238-33-9	0.92	1-Ethyl-2-Propyl Cyclohexane
70657-70-4	1.12	2-Methoxy-1-propyl Acetate
74392-33-9	2.78	Trans-5-Pentadecene
75736-67-3	0.80	1-Methyl-4-Pentyl Cyclohexane
82144-67-0	0.71	3,7-Dimethyl Dodecane
84540-57-8	1.97	methoxypropanol acetate
88917-22-0	1.49	Dipropylene glycol methyl ether acetate
89399-28-0	2.09	2-methoxy-1-(2-methoxy-1-methylethoxy)-propane
92031-93-1	0.67	1-Methyl-2-Hexyl-Cyclohexane
94023-15-1	1.79	2-tert-Butoxy-1-Propanol
111823-35-9	3.26	3-Methyl-2-Isopropyl-1-Butene
164259-42-1	1.08	1,3-Diethyl-5-Methyl Cyclohexane
164259-43-2	1.03	1,3,5-Triethyl Cyclohexane
175032-36-7	0.55	4,8-Dimethyl Tetradecane
205324-73-8	0.58	trans 1-Methyl-4-Heptyl Cyclohexane

**Appendix G****Diurnal Emissions Comparison**

The difference in permeation measured when Fuel B (with ethanol) was tested, compared to Fuel A is presented in Table 20. The average permeation increased on all ten rigs when the fuel was switched from the MTBE oxygenate fuel (Fuel A) to the ethanol oxygenate fuel (Fuel B). The increase ranged from 0.34 g/day to 2.71 g/day, with an average increase of 1.40 g/day.

Table 20  
**Comparison of Diurnal Permeation Rates Between Fuel A and Fuel B**

Rig	Vehicle	Tank	Increase: Fuel A to Fuel B	
			g/day	%
1	2001 Toyota Tacoma	15.8 gal - Metal	0.52	216.2
2	2000 Honda Odyssey	20.0 gal - Plastic	0.79	124.6
3	1999 Toyota Corolla	13.2 gal - Metal	1.08	374.3
4	1997 Chrysler Town & Country	20.0 gal - Plastic	1.62	258.9
5	1995 Ford Ranger	16.5 gal - Plastic	2.45	26.6
6	1993 Chevrolet Caprice Classic	23.0 gal - Plastic	0.34	7.4
7	1991 Honda Accord LX	17.0 gal - Metal	1.02	82.0
8	1989 Ford Taurus GL	16.0 gal - Metal	1.67	173.7
9	1985 Nissan Sentra	13.2 gal - Metal	2.71	138.0
10	1978 Olds Cutlass Supreme	18.1 gal - Metal	1.82	94.7
<b>Average</b>			<b>1.40</b>	<b>149.7</b>

The difference in permeation measured when Fuel B (with ethanol) was tested, compared to Fuel C (no oxygenate) is presented in Table 21. The increase ranged from -0.15 g/day to 2.90 g/day, with an average increase of 1.10 g/day.

Table 21  
**Comparison of Diurnal Permeation Rates Between Fuel B and Fuel C**

Rig	Vehicle	Tank	Increase: Fuel C to Fuel B	
			g/day	%
1	2001 Toyota Tacoma	15.8 gal - Metal	0.54	241.7
2	2000 Honda Odyssey	20.0 gal - Plastic	0.85	145.2
3	1999 Toyota Corolla	13.2 gal - Metal	1.04	314.6
4	1997 Chrysler Town & Country	20.0 gal - Plastic	1.12	98.7
5	1995 Ford Ranger	16.5 gal - Plastic	-0.15	-1.3
6	1993 Chevrolet Caprice Classic	23.0 gal - Plastic	1.18	31.7
7	1991 Honda Accord LX	17.0 gal - Metal	0.34	17.8
8	1989 Ford Taurus GL	16.0 gal - Metal	1.80	218.2
9	1985 Nissan Sentra	13.2 gal - Metal	2.90	163.6
10	1978 Olds Cutlass Supreme	18.1 gal - Metal	1.43	62.3
<b>Average</b>			<b>1.10</b>	<b>129.3</b>

Finally, a comparison of the permeation results from Fuel C compared to Fuel A is offered in Table 22. The increase ranged from -0.84 g/day to 2.60 g/day, with an average increase of 0.30 g/day.

Table 22  
**Comparison of Diurnal Permeation Rates Between Fuel A and Fuel C**

Rig	Vehicle	Tank	Increase: Fuel A to Fuel C	
			g/day	%
1	2001 Toyota Tacoma	15.8 gal - Metal	-0.02	-7.5
2	2000 Honda Odyssey	20.0 gal - Plastic	-0.05	-8.4
3	1999 Toyota Corolla	13.2 gal - Metal	0.04	14.4
8	1989 Ford Taurus GL	16.0 gal - Metal	-0.13	-14.0
9	1985 Nissan Sentra	13.2 gal - Metal	-0.19	-9.7
		Group Average	-0.07	-5.04
4	1997 Chrysler Town & Country	20.0 gal - Plastic	0.51	80.6
5	1995 Ford Ranger	16.5 gal - Plastic	2.60	28.3
6	1993 Chevrolet Caprice Classic	23.0 gal - Plastic	-0.84	-18.4
7	1991 Honda Accord LX	17.0 gal - Metal	0.67	54.4
10	1978 Olds Cutlass Supreme	18.1 gal - Metal	0.38	20.0
		Group Average	0.66	33.0
		<b>Overall Average</b>	<b>0.30</b>	<b>14.0</b>

Table 22 shows two groups of rigs – the upper set contains test results where the difference between Fuel A and Fuel C was minor (average of -0.07 g/day, and 5.0% of level). The lower set indicated a larger difference (0.66 g/day and 33%) between the diurnal permeation results of the two fuels.

**Appendix H****Individual Laboratory Fuel Inspections****CRC E-65 Permeation Study Individual Laboratory Fuel Inspections**

Inspection	Units	Fuel A -- CARB 2 MTBE					Fuel B -- CARB 3 Ethanol					Fuel C -- CARB 2 Non-Oxy				
Laboratory		A	B	C	D	Average	A	B	C	D	Average	A	B	C	D	Average
API Gravity	°API	58.8	58.7	58.7	58.9	58.8	58.2	58.1	58.1	58.2	58.2	61.1	60.9	60.9	61.1	61.0
Relative Density	60/60°F	0.7436	0.7440	0.7441	0.7432	0.7437	0.7459	0.7463	0.7463	0.7459	0.7461	0.7347	0.7354	0.7356	0.7349	0.7
DVPE	psi	7.10	6.88	6.98	7.24	7.1	7.12	7.10	6.98	7.28	7.12	7.06	6.93	6.95	7.16	7.0
Oxygenates--D 4815																
MTBE	vol%	9.7	9.88	9.85	10.1	9.88	<0.1	0.04	0.0	<0.1	<0.1	0.1	0.07	0.0	0.0	0.04
TAME	vol%	1.2	1.42	0.95	0.9	1.13	<0.1	0.00	0.0	<0.1	<0.1	0.1	0	0.0	0.0	0.02
EtOH	vol%	0.0	0.00	0.00	0.0	0.00	5.4	5.61	5.48	5.3	5.5	<0.1	0	0.0	0.0	0.0
O2	wt%	1.96	2.03	1.95	1.99	1.98	2.01	2.08	2.03	1.96	2.02	0.02	0.01	0.0	0.0	0.0
FIAM Corrected--D 1319																
Aromatics	vol%	22.6	22.0	24.15	-	22.9	27.9	24.0	25.7	-	25.9	27.6	26.2	26.3	-	26.7
Olefins	vol%	5.8	4.4	4.69	-	5.0	7.3	4.9	5.2	-	5.8	6.7	5.8	5.4	-	6.0
Saturates	vol%	60.7	62.3	60.36	-	61.1	59.4	65.5	63.6	-	62.8	65.5	68.0	68.3	-	67.3
Oxygenates	vol%	10.9	11.3	10.8	11.0	11.0	5.4	5.65	5.48	5.3	5.5	0.2	0.07	0.0	0	0.07
Aromatics--D 5580																
Benzene	vol%	0.52	-	0.53	0.55	0.53	0.70	-	0.71	0.74	0.72	0.75	-	0.72	0.72	0.73
Toluene	vol%	8.33	-	8.27	8.17	8.26	7.02	-	6.79	6.90	6.90	8.59	-	8.44	8.36	8.46
Ethylbenzene	vol%	0.98	-	0.83		0.91	1.20	-	1.03		1.12	1.54	-	1.35		1.45
p/m-Xylene	vol%	4.00	-	3.63	6.54 <sup>a</sup>	3.82	5.12	-	4.71	8.2 <sup>a</sup>	4.91	5.84	-	5.57	9.66 <sup>a</sup>	5.71
o-Xylene	vol%	1.45	-	1.38		1.42	1.77	-	1.75		1.76	2.12	-	2.10		2.11
C9+	vol%	8.91	-	-	8.26	8.59	10.28	-	-	9.98	10.13	8.36	-	-	6.88	7.62
Total	vol%	24.31	-	-	24.20	24.26	26.08	-	-	26.40	26.24	27.20	-	-	27.20	27.20

<sup>a</sup> C8 aromatics

**Appendix H**

**Individual Laboratory Fuel Inspections (Cont)**

**CRC E-65 Permeation Study Individual Laboratory Fuel Inspections**

Inspection		Units	Fuel A -- CARB 2 MTBE					Fuel B -- CARB 3 Ethanol					Fuel C -- CARB 2 Non-Oxy				
Laboratory			A	B	C	D	Average	A	B	C	D	Average	A	B	C	D	Average
D 86 Distillation																	
	IBP	°F	99.5	101.3	101.8	100.1	100.7	111.3	110.2	105.26	107.2	108.5	101.1	100.7	102.0	100.2	101.0
	5% Evaporated	°F	126.3	126.5	128.8	122.7	126.1	130.4	128.9	127.76	127.9	128.7	129.5	130.6	126.1	125.7	128.0
	10% Evaporated	°F	136.4	136.0	137.5	133.2	135.8	135.3	133.9	132.62	133.5	133.8	137.6	138.5	135.0	134.2	136.3
	20% Evaporated	°F	148.4	147.7	149	146	147.8	140.9	139.3	140	140.2	140.1	149.5	149.4	146.7	146.2	147.9
	30% Evaporated	°F	161.6	160.7	162	158.6	160.7	160.8	156.8	152.06	152	155.4	162.8	161.7	158.7	158.4	160.4
	40% Evaporated	°F	177.8	175.6	177.4	175.1	176.5	186.9	184.8	181.94	184.3	184.5	178.1	176.5	173.5	173.7	175.4
	50% Evaporated	°F	196.8	195.1	196.9	194.2	195.7	204.6	203.4	201.2	201.8	202.8	195.9	194.4	190.8	191.2	193.1
	60% Evaporated	°F	221.0	218.5	219.9	217.5	219.2	220.1	219.0	216.32	218.1	218.4	216.6	214.4	211.1	211.1	213.3
	70% Evaporated	°F	245.3	242.6	244.4	242.6	243.7	237.3	236.2	234.86	234.7	235.8	239.7	237.6	233.4	234.5	236.3
	80% Evaporated	°F	271.4	269.8	270	269	270.0	262.2	261.1	260.24	261.1	261.2	265.1	263.4	260.1	261	262.4
	90% Evaporated	°F	309.5	308.8	308.3	308.7	308.8	304.7	303.4	302.54	305.4	304.0	301.2	298.4	295.3	296.8	297.9
	95% Evaporated	°F	334.7	333.3	332.6	333.1	333.4	332.6	333.9	328.64	333.5	332.2	330.9	323.9	320.4	320.7	324.0
	EP	°F	375.6	370.6	369.9	375.9	373.0	391.8	394.6	369.68	386.8	385.7	368.9	374.7	355.8	365.8	366.3
	Recovery	vol%	97.1	97.3	98.3	96.7	97.4	98.7	98.2	97.7	97.9	98.1	97.7	98.2	97.6	97.9	97.9
	Residue	vol%	1.2	1.2	0.9	2.1	1.4	1.0	0.8	1.1	1	1.0	1.0	0.7	0.9	1.1	0.9
	Loss	vol%	1.7	1.5	0.8	0.9	1.2	0.3	1.0	1.2	1	0.9	1.3	1.1	1.5	0.9	1.2
Gum																	
	Unwashed	mg/100ml	17.6	-	-	16	16.8	20.0	-	-	18.2	19.1	20.0	-	-	17	18.5
	Washed	mg/100ml	1.0	-	-	1	1.0	0.0	-	-	1	0.5	0.0	-	-	1.2	0.6
Sulfur		ppm	25.0	27.0	-	25.0	25.7	14.0	16.0	-	14.0	14.7	18.0	18.0	-	17.0	17.7